

HMI A2

Machine Interface

Datasheet

Description

HMI A2 is an interface module equipped with a 20x4 alphanumeric display and a 13 buttons keyboard. This unit, designed for panel mounting and housed in a rugged metal case.

Main characteristics:

- Monochromatic display (white over blue) 20 characters x 4 rows
- 13 buttons integrated keyboard.

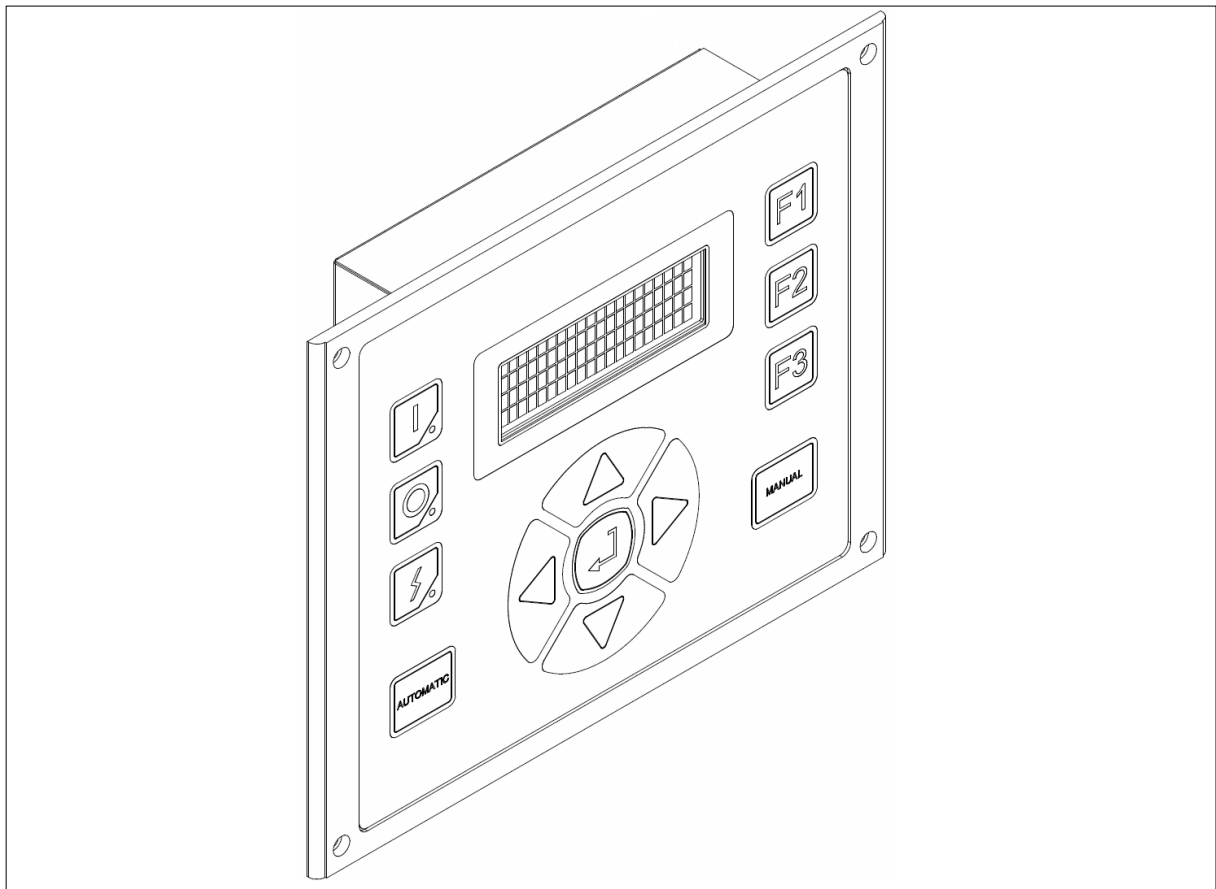

Ordering informations

Products	SMITEC part number
HMI A2 module	Depending on firmware version installed – contact us

Accessories	SMITEC part number
Power supply connector (Phoenix Contact p/n 1851041)	KF101052

Documentation	SMITEC part number
Datasheet for HMI A2 (english)	DK400145

Technical data

General data	
Housing dimensions (width x height x depth)	210 mm x 170 mm x 36,3 mm
Weight	450 g
Permissible operating temperature	+5° to +55°C
Permissible storage and transport temperature	-25° to +85°C
Permissible humidity	10% to 95%, not condensing
Permissible air pressure (operation)	80 to 106 kPa (up to 2000 m above sea level)
Permissible air pressure (storage and transport)	70 to 106 kPa (up to 3000 m above sea level)
Rear degree of protection	IP20 according to IEC 60529
Front degree of protection	IP65 according to IEC 60529 (when flush mounted)
Connection method for power connector	Spring cage terminals
Conductor cross-section for power connector	0.14 to 1.5 mm ² (26 – 16 AWG)
Functional earth connection	To the Faston contact
Mode state visual indicators	Green, red and blue LED lamps on front side

Power supply	
Main power supply V_M	24 V DC (-15% ÷ + 20% according to IEC 61131-2)
Maximum allowed ripple	5% of supply voltage (according to IEC 61131-2)
Current consumption from main supply	0,25 A max.
Supply overvoltage protection on V_M	Unidirectional Zener clamp ($V_z > 30$ V)
Supply reverse polarity protection	Input shunt diode, reverse connected
Supply fuse	1 A

Mechanical drawing

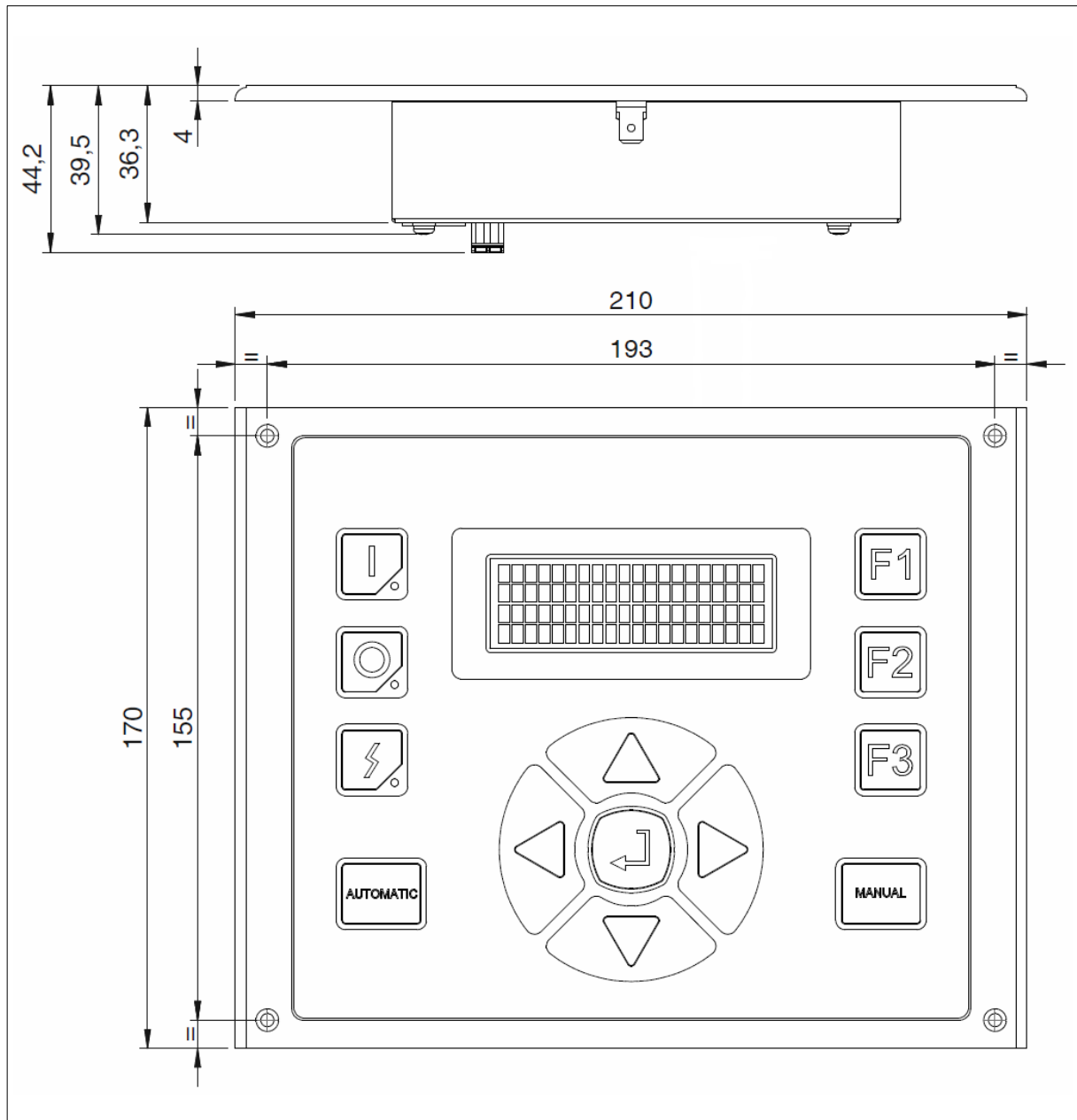

Connections

The module HMI A2 has several connectors for connecting peripherals and the power supply. All connectors are located on the rear side of the module (power supply, RJ45 and Box header connector).



Warning: HMI A2 module is an electronic high technology device with numerous connectors; for these reasons it result a ESD sensitive device. Observe ESD mitigation techniques or damage might occur.

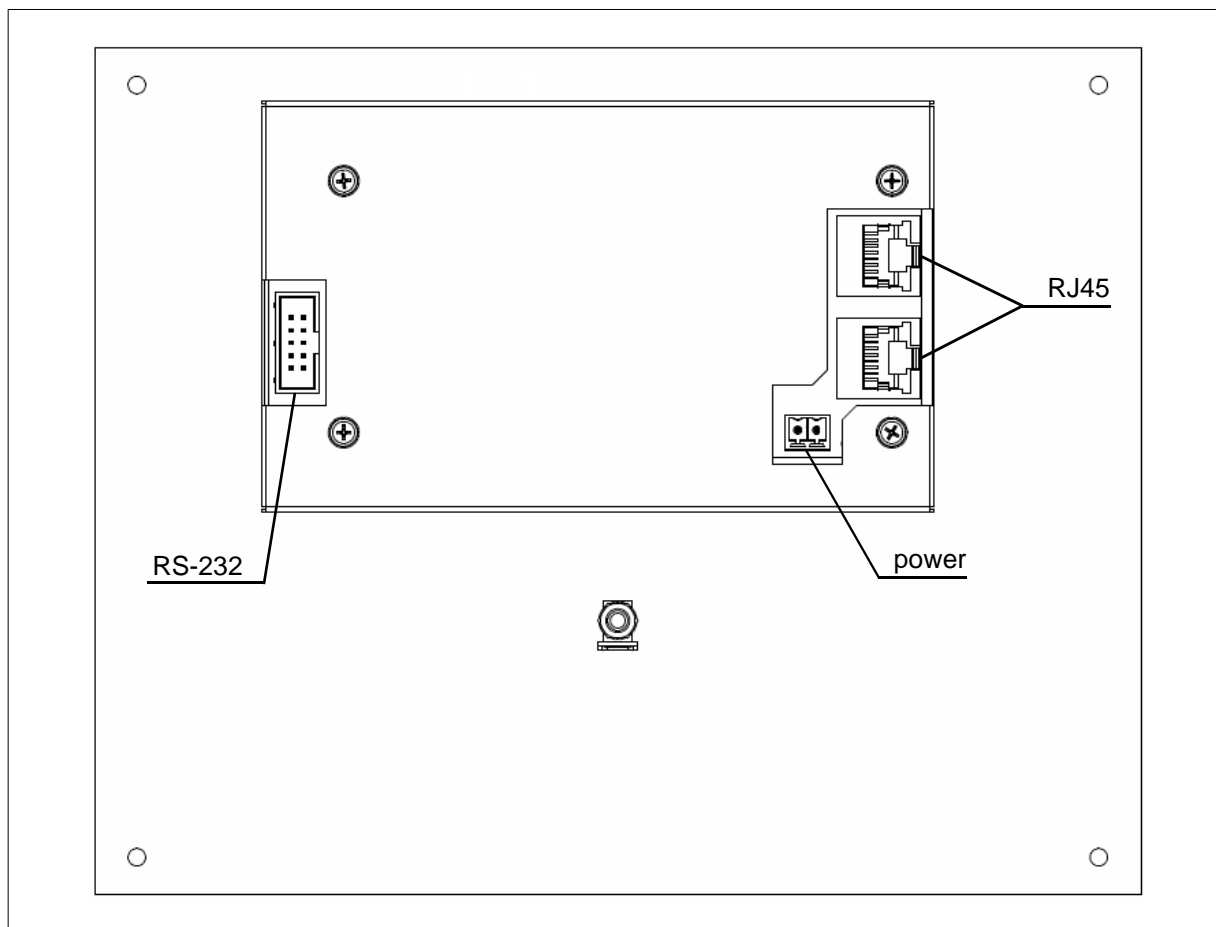

Power connector

The power connector is located on the rear side of the module. Here its pinout:



Warning: Use a cable with cross-section suited to the current involved. A wire smaller than necessary could cause risk of fire and unwanted voltage drops.



Warning: To ensure conformance with EMC directive 89/336/EEC, the length of the cables must not exceed 30 m!

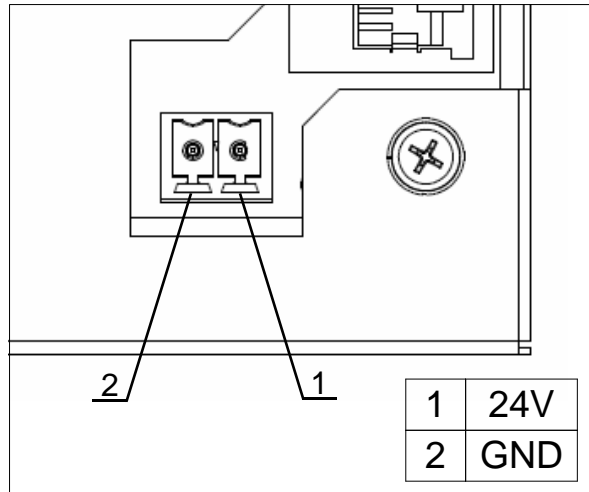

RJ45 connectors

The RJ connectors are located on the rear side of the module.

The connectors are available in cascable version.

The up RJ connector must be connected to the CPU module, the down one is used to have a second display in cascade.

For these connectors use the standard RJ45 cable.

RS-232 connector

The RS-232 connector is located on the rear side of the module.

This is a boxed connector that is used to program this module or as a RS-232 serial port for exchanging data. Here its pinout:

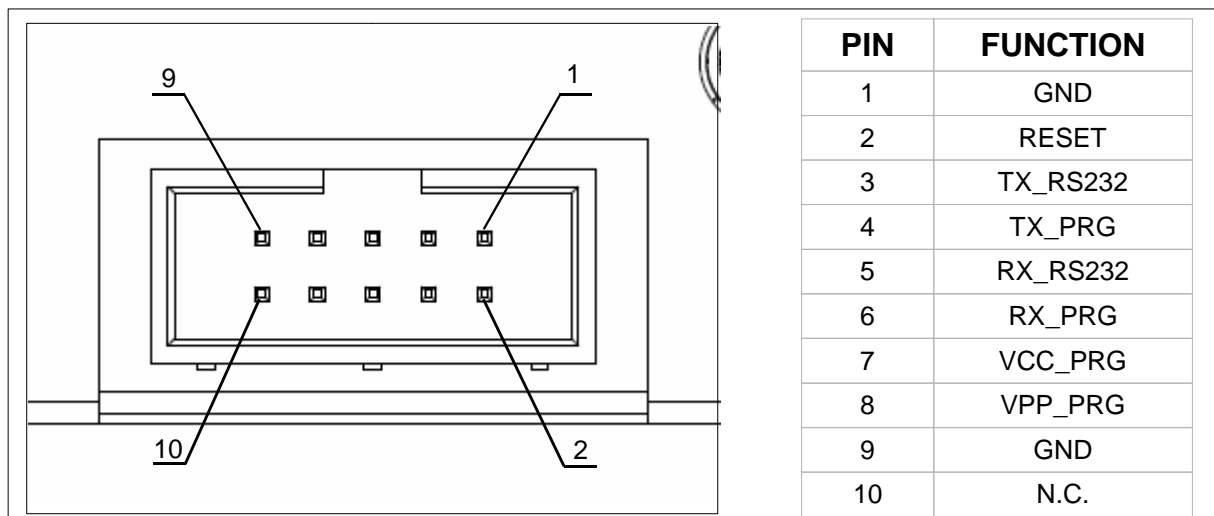

Status indicators

Each module is provided with 3 LED lamps; leds can have various meanings, depending on the firmware on board.

For example:

- Green: Run
- Red: Stop
- Blue: Power supply is present.

