

# P-GATE SIII

## Quad DC brush motor driver with Hall sensors interface

Datasheet

### Description

Driver module for DC brush motors, quad output and interface for Hall sensors. Main characteristics:

- Quad power output with MOSFET H-bridge.
- PWM control with software programmable frequency.
- Hall sensors interface for speed/position control.
- SERCOS III interface for real-time control.
- Industry standard M12 connections.
- Compact IP65 plastic housing.

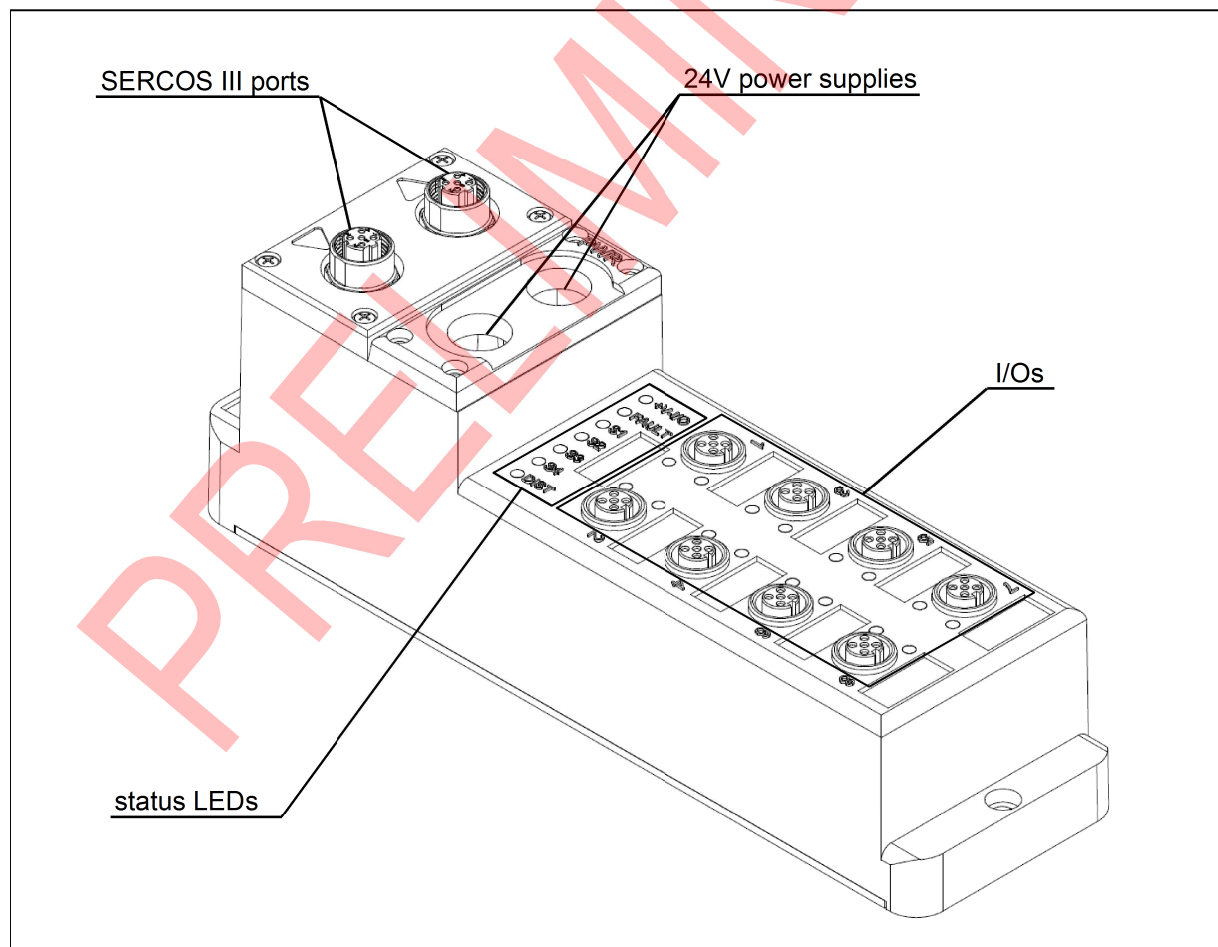

---

## Ordering informations

<b>Products</b>	<b>SMITEC part number</b>
I/O module P-Gate SIII	KZ010351

<b>Accessories</b>	<b>SMITEC part number</b>
Power supply connector (Weidmuller 1580450000)	KF100000
M12 sealing plug	EP200068
PG-9 cable gland (for power supply connector)	EK500055
PG-9 sealing plug	EK500223
12.5 A fast 5 x 20 mm fuse	KD200004

<b>Documentation</b>	<b>SMITEC part number</b>
Datasheet for KZ010351 (english)	DK400099

## Technical data

General data	
Housing dimensions (length x width x height)	220 x 63 x 72 mm
Weight	0.53 kg
Permissible operating temperature	+5°C to + 55°C
Permissible storage temperature	-40°C to +70°C
Permissible humidity	5% to 95%, not condensing
Permissible air pressure (operation)	80 to 106 kPa (up to 2000 m above sea level)
Permissible air pressure (storage)	70 to 106 kPa (up to 3000 m above sea level)
Degree of protection	IP65 according to IEC 60529
Wiring method for power supply connector	Screw terminals
Conductors cross-section	0.1 to 2.5 mm <sup>2</sup> (27÷12 AWG), stranded wire
Functional earth connection	By supply connector

Power supplies	
Number of supplies	2
Logic power supply	20.4 ÷ 28.8 VDC according to IEC 61131-2
Maximum allowed ripple on logic supply	5% of nominal voltage according to IEC 61131-2
Current consumption on logic supply	400 mA max.
Overcurrent protection on logic supply	PTC resettable fuse
I/O power supply	20.4 ÷ 28.8 VDC according to IEC 61131-2
Maximum allowed ripple on I/O supply	5% of nominal voltage according to IEC 61131-2
Current consumption on I/O supply	Depending on external loads.
Overcurrent protection on I/O supply	5 x 20 mm fuse, 12.5 A max.
Main power connector current carrying capacity	12 A max for each contact.

Power outputs	
Number of motor outputs	4
Output configuration	MOSFET H-bridge, PWM controlled
Type of load	24 V DC brush motors
Output current for each output	5.5 A (one output only), 4 A (two outputs)
Total output current	8 A max.
PWM range	0 ÷ 100%, forward and reverse
Isolation between channels	none
Output state visual indicators	One amber LED lamp for each output, lighted if the corresponding output is enabled

Hall sensors inputs	
Number of inputs	4 (two sensors for each motor)
Input configuration	For open collector sensors with 1.5 kΩ integrated pull-up resistor, 24 V tolerant

Inputs logic levels	$V_L = 2.0 \text{ V max.}$ , $V_H = 3.0 \text{ V min.}$ , Schmitt triggered
Input frequency range	Up to 4 kHz
Hall sensors supply	$5 \text{ V} \pm 10\%$ , 100 mA max., short circuit protected
Visual indicators	Two amber LEDs for each input, indicating forward or reverse direction of rotation.

<b>Fieldbus</b>	
Fieldbus	SERCOS III
Module address setting	Auto assignment
Bus connections	By D-coded M12 connectors

PRELIMINARY

---

## Introduction

This module is devised to drive up to four 24 V DC brushed motors; whenever equipped with single or twin Hall sensor, speed and/or position control is obtainable.

Power MOSFETs H-bridges allow four-quadrants driving of the motors, and PWM modulation permits to set the speed of the motor at any desired value.

Designed in accordance to IEC 61131-2 international standard, this module is able to interoperate with the great majority of devices in typical industrial installations.

Robust and reliable real-time control is obtainable using Ethernet-based SERCOSIII protocol.

Small size and sealed housing render it particularly suited for a mounting on the machine's chassis, reducing the length of the cables.

## Connections

This module has several connectors for the power supplies, the I/Os and the fieldbus (depicted in the illustration). See the following chapters for a more detailed description of these.

## Power supplies

The power supply connector is easily reachable removing the small plastic plate located on the upper side of the housing, secured by four M3 crosshead screws. Cable sealing is obtained using two PG-9 cable glands; whenever only one cable is used, seal the unused opening screwing in the suited sealing plug. The device needs two different power supplies: one feeds the logic section of the device, and one the external sensors/actuators; this I/O supply is provided with an internal 5 x 20 mm fuse acting as an overcurrent/overload protection. In case of

replacement, never exceed the maximum rating or damage might occur. In several situations, it is customary to use an UPS to backup the logic power supply, particularly whenever the I/O supply could be interrupted by external events (e.g. an emergency button or a door switch). If the user doesn't need this feature, the two supplies can be shorted together.

If several modules should be fed by the same power supply, two different wiring topologies could be employed: a point-to-point and a daisy-chain topology. Point-to-point wiring means that each device is fed by the PSU via its own cable; all cables are tied together at the origin.

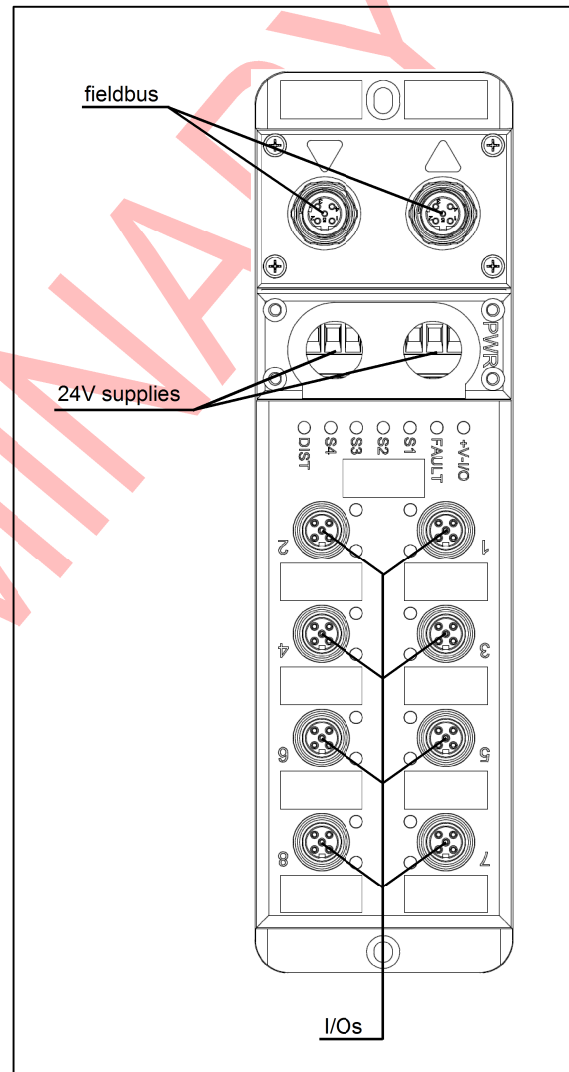

Daisy-chaining stands for a series connection of the modules; each of them is fed by the previous device and, in turn, it feeds the following one. This topology is particularly useful when there are many devices and/or they are very far from the PSU. The principal drawback of this kind of wiring is that the upstream conductor has to bear the whole current, so this topology can be used only where the total power is limited. Whenever the total current flows through a connector, special care has to be exerted to avoid damaging of this one, especially during a fault.

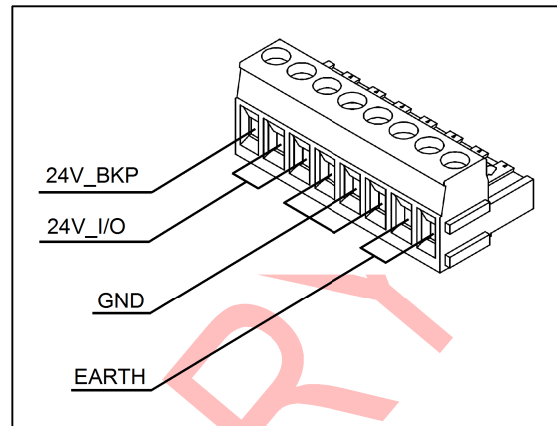

The pinout of the supply connector is depicted aside; as previously stated, power supply pins are split, so easing wiring in a daisy-chaining fashion.

Please notice the presence of a separated earth contact, used to connect the shield of the I/O cables and for EMC filtering purposes.

To avoid failures or incorrect operation of the modules, the PSU ground should be equipotential with earth; to avoid the generation of detrimental ground loops, the ground contact should be earthed only once in the electrical cabinet, and the impedance of the earth connections should be kept low enough to effectively drain RF noise.

The following illustration shows the recommended wiring for point-to-point topology:

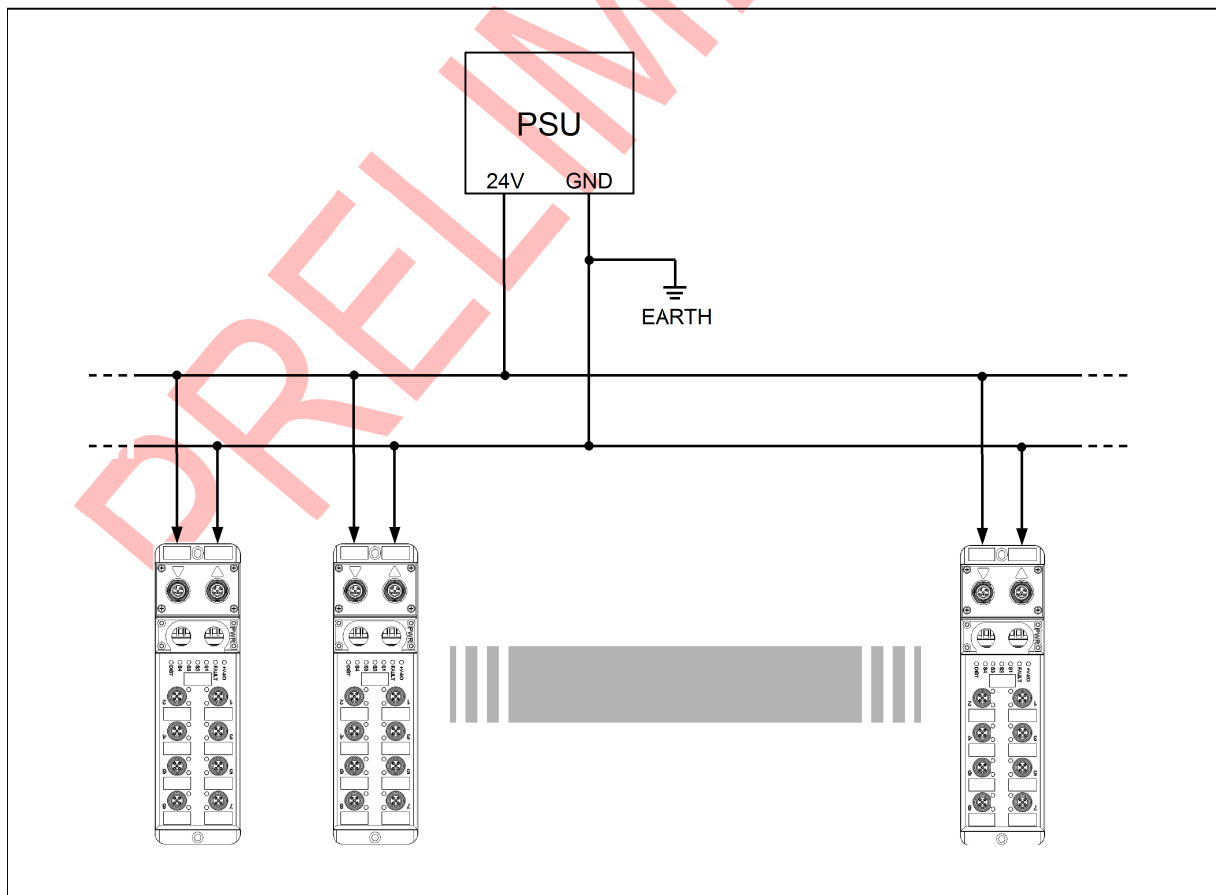

An example of daisy-chain topology is instead depicted in the following illustration; for simplicity, in each example only one PSU is shown.

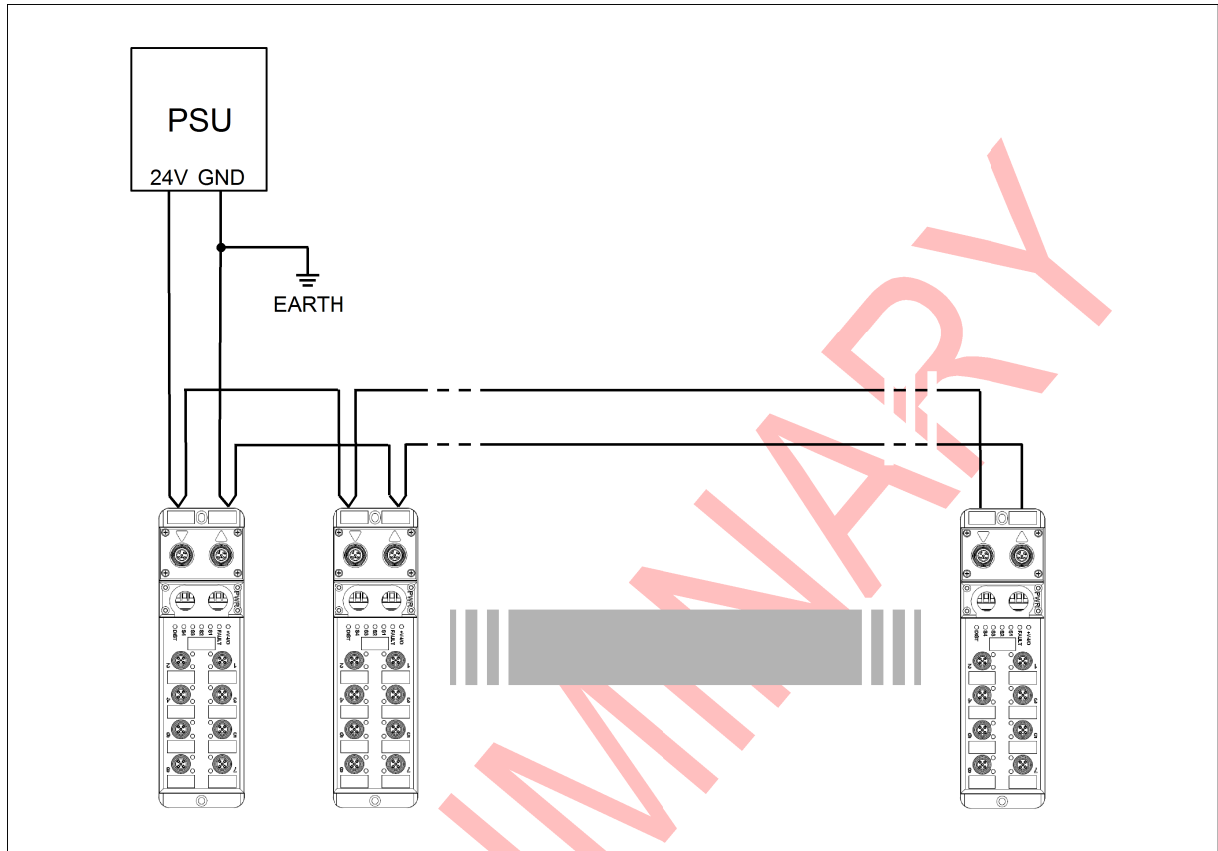

Whenever necessity of split power supplies arises (eg. when using a backup logic supply), the same wiring rules apply to each one.

### Inputs/Outputs

This module is provided with eight M12 connectors I/Os (see illustration); the first row of

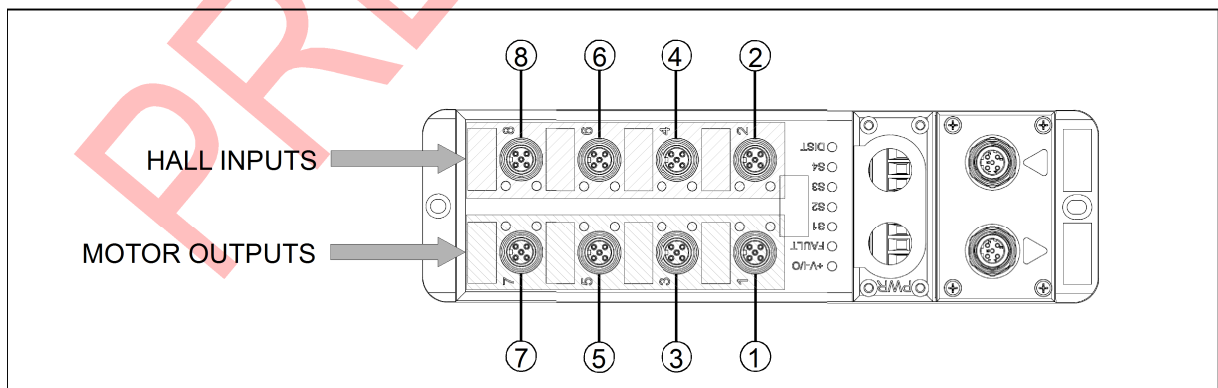

connectors (1, 3, 5 and 7) is for the motors and the second row (2, 4, 6 and 8) is for the Hall sensors. Each connector is marked with a number molded in relief on the housing; the

numbering pattern is shown in the illustration. The pinout is resumed in the following table:

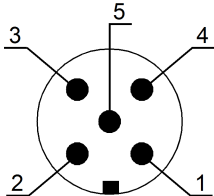

CONNECTOR NUMBER		
PIN NUMBER	1, 3, 5, 7	2, 4, 6, 8
1	<i>GND</i>	<i>5V</i>
2	<i>Motor out -</i>	<i>Hall B input</i>
3	<i>GND</i>	<i>GND</i>
4	<i>Motor out +</i>	<i>Hall A input</i>
5	<i>shield</i>	<i>shield</i>

The following paragraphs are devoted to illustrate the correct wiring of motors and sensors, showing hints and tricks to make the application running.

## Motors

This module is designed to drive brushed DC motors only, having a nominal voltage of 24 V. Less than 24 V rated motors are useable, providing that the PWM value is limited accordingly and the device can withstand the voltage applied; anyhow, this arrangement is not recommended.

Due to physical construction, DC motors are prone to EMI generation, caused by the sparkling on the collector. This peculiar behaviour is usually accounted for by the makers, usually inserting noise-suppressing capacitors across the brushes. Even whether this arrangement is effective towards the noise, it creates a capacitive loading on the MOSFET outputs, particularly detrimental when operating in PMW. The abrupt and repeated charging and discharging of these capacitors leads to a dramatic increase of the commutation losses inside the module, also raising the peak current during commutations. In extreme cases, the module couldn't even start through exceeding its overcurrent threshold. Proper remedies are:

- Remove capacitors from the motor or reduce capacitance value.
- Replace capacitors with RC suppression networks.
- Reduce PWM switching frequency (whenever possible).
- Derate the available output current to account for losses.
- Insert choke coils in series to reduce peak current.

The following illustration depicts the recommended wiring for motors; ordinary non-shielded cable is usually suited for the purpose. Nevertheless, fast commutations and spark-induced noise could lead to high levels of EMI disturbances; if this is the case, fix the problem using shielded cable. The sheath should preferably earthed at both sides, keeping the unshielded length of the internal wires as short as possible. Please be aware that a high level of sparking



---

might be caused by wearing of the brushes or damaged collector, so replace defective parts first.

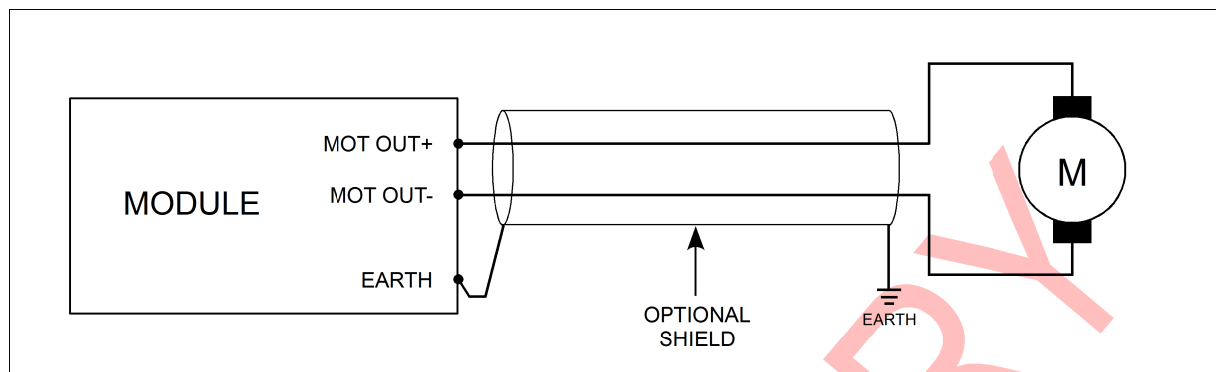

The wire cross-section should be suited to carry the current involved without excessive heating. Besides, the voltage drop along the cable should be kept low, especially in case of long distances; this might lead to the use of a larger copper cross-section.

Even if the module is intrinsically protected against short circuit or overcurrent, it is responsibility of the user to protect cables and/or loads against these occurrences. This is particularly of concern when a motor could be overloaded during operation, due to mechanical failures (e.g. seizing of bearings) or other reasons. In this situation, it is advisable to insert a protection device (e.g. a fuse or a thermal switch) to avoid damage. If the current exceeds the capability of the internal 5 x 20 mm fuse, it will blow and protect the module; in this case, always replace it with the original spare part.

### Hall sensors

Several industrial applications require an accurate measuring and control of speed and/or position; this task require a device behaving like an encoder, and DC brush motors are often equipped with Hall sensors.

The simpler control is accomplished mounting only one sensor, usually driven by a magnet. Because these sensors change their logic state when the magnetic field exceeds their own threshold (usually a certain amount of hysteresis is added to prevent multiple commutations), counting the number of edges of the waveform permits to calculate the speed of the shaft. Even whether this system is usually accurate enough for applications where the motor revolves only in one way, it will lack precision when the shaft can rotate in both directions. This happens because the sensor meters only the number of steps, independently of the clockwise or counterclockwise rotation of the shaft.

The two sensors arrangement supersedes these limitations, mounting two mechanically-spaced sensors and acquiring both signals. The spacing is selected to assure that the two signals (usually named A and B) have a phase shift of 90°, when the shaft is spinning at a fixed speed. Looking at the relationship between the signals, it is easy to detect the direction of rotation; the following illustration depicts the waveforms in both cases.

This arrangement is exempt from counting errors, e.g. due to mechanical vibrations on a motionless shaft; even when one sensor could change state, there is virtually no risk of measuring the position wrongly.

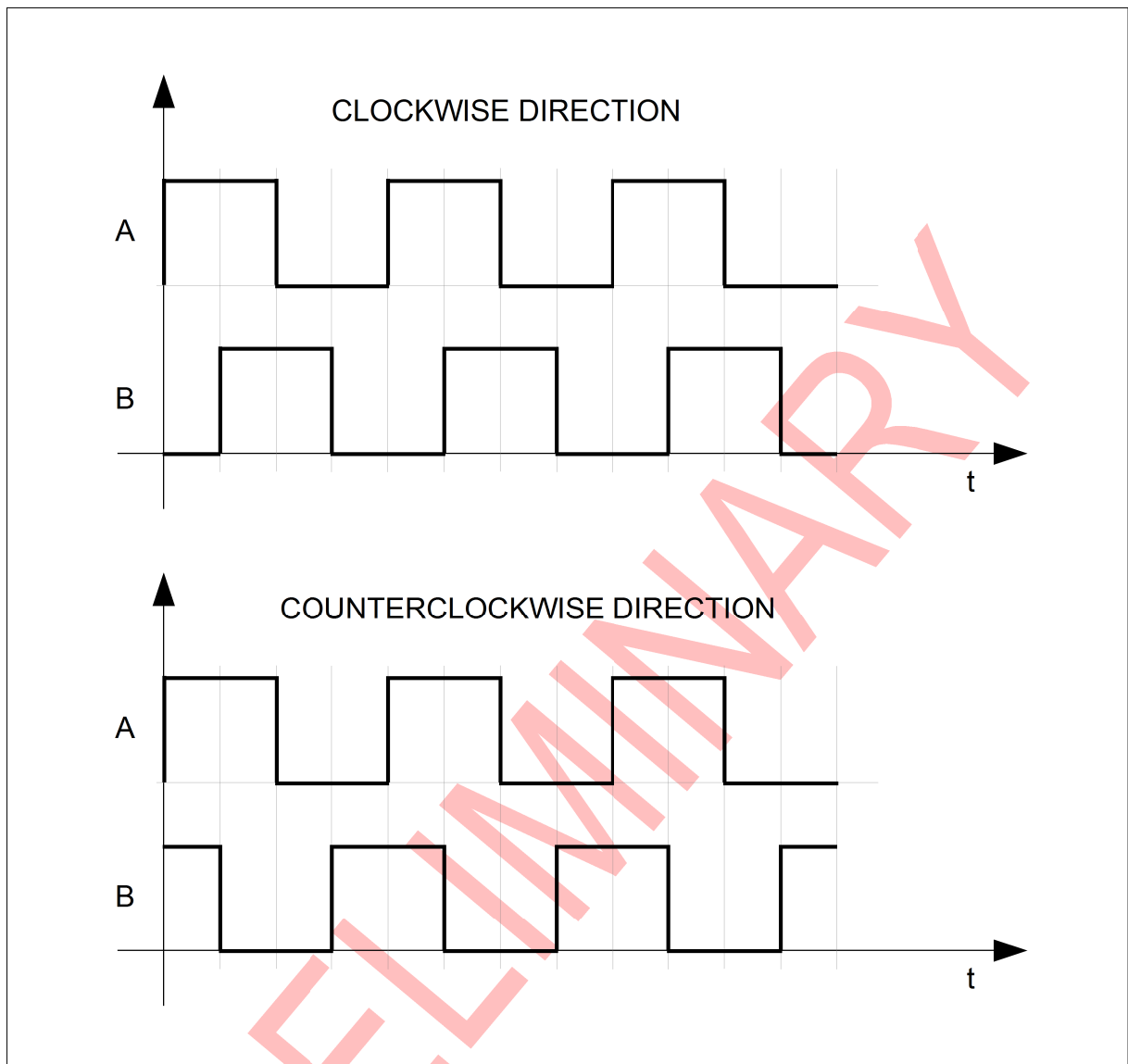

The inputs of the module are tailored for the widespread open-collector Hall sensors; the 5 V supply is provided on the same M12 connector and an integrated 1.5 k $\Omega$  pull-up resistor is integrated on board. In the following illustration, a recommended wiring pattern for twin sensors is shown. Due to the relative low levels of the signals involved and the high level of disturbances often found in harsh industrial environments, the use of shielded cable is highly recommended; the cable sheath should be tied to earth preferably at both sides, and the central pin of the M12 connector provides an earth contact for this purpose. If the use of ordinary unshielded wire is unavoidable, route the cables as far as possible from any source of noise as motor cables, switching power supplies, relays, etc..

In most applications the sensors are fed by the 5 V supply provided on the M12 connector; the current capability is adjusted to fit standard low-power sensors. In any case be careful not to exceed the maximum rating or the overcurrent protection will intervene.

The peculiar design of the inputs renders them 24 V tolerant, so accepting standard 24 V output industrial sensors without damage; even though this connection is not recommended

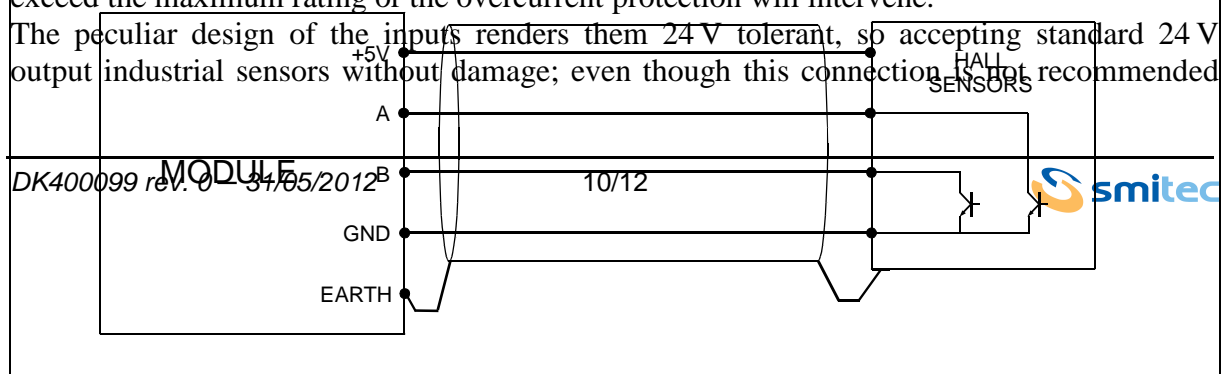

due to the reduced noise margins, this arrangement is feasible. In this case, feed the sensors with an external 24 V supply with the same ground of the module's supply (possibly the same used for it), and make the wiring as best as you can. To assure a consistent noise margin, the output voltage of the sensor when in logic state “0” must be low enough respect to the low threshold of the module (named  $V_L$ ) in the specifications. The 5 V pin must be left unconnected. If the output is open-collector, a suited external pull-up resistor should be tied to 24 V.

## I/O status indicators

A series of indicators is provided on the upper part of the module, to show the condition of each motor (for the dislocation see the picture in the following). A total of 12 amber LED lamps is fitted, three for each motor; the following table resumes all the possible states using a motor equipped with one or two Hall sensors:

CONDITION \ INDICATOR	POWER	FORWARD	REVERSE
motor disabled and still	<i>off</i>	<i>off</i>	<i>off</i>
motor disabled and running forward	<i>off</i>	<i>on</i>	<i>off</i>
motor disabled and running reverse	<i>off</i>	<i>off</i>	<i>on</i>
motor enabled and still	<i>on</i>	<i>off</i>	<i>off</i>
motor enabled and running forward	<i>on</i>	<i>on</i>	<i>off</i>
motor enabled and running reverse	<i>on</i>	<i>off</i>	<i>on</i>

More in detail, the direction LEDs (FORWARD and REVERSE) are turned on when one or more pulses are detected in the corresponding direction, and stay lighted for one second after the last edge detection. Whenever the motor has no feedback sensors, these LEDs are always turned off.

Please notice that the direction of spinning depends on the convention used and on the physical construction of the motor.

## Fieldbus

This module is provided with an Ethernet interface; the connections of the fieldbus are available through two purposely made D-coded M12 connectors; the pinout is depicted in the illustration. The wiring of the fieldbus network should be done with standard CAT 5E Ethernet cable. Due to the address auto-assignment system, the wiring order of the modules should be respected or an erroneous addressing will result. The two arrows etched aside the fieldbus connectors indicate that this cable come from the preceding device or goes to the next device.

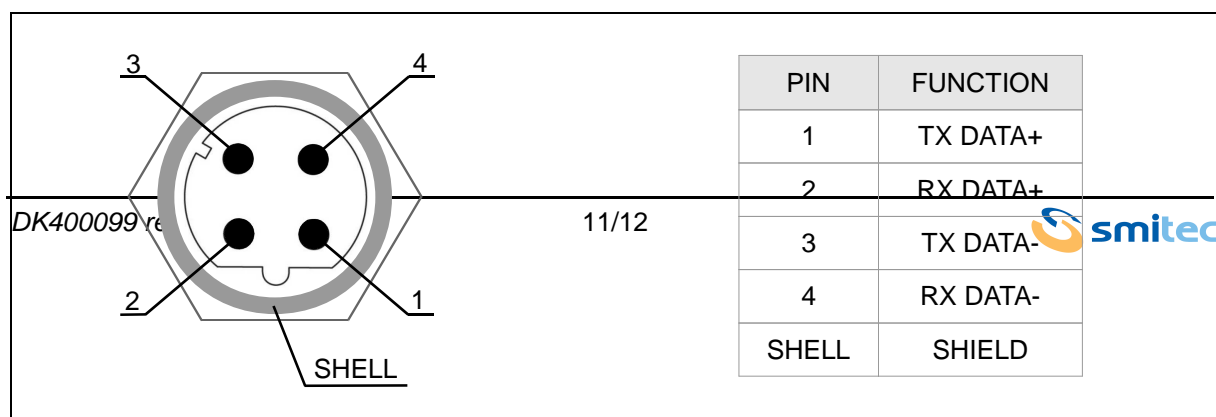

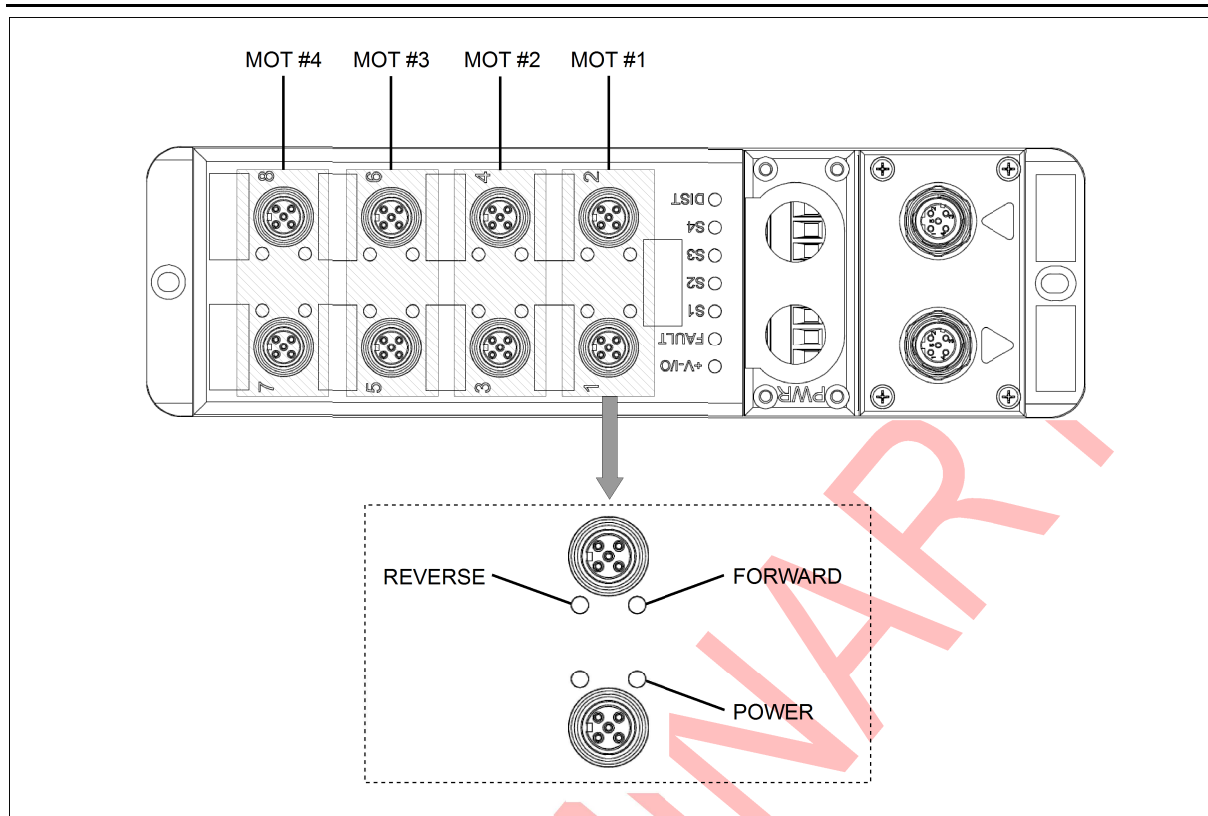

## Module status

The status of the module is clearly shown by the status of six LED lamps; their colour and behaviour (being them turned on, turned off or blinking in a definite manner) indicate if the unit is working correctly or it is faulty and, in this case, where the problem lies.

The 24V\_I/O lamp is lighted when the main power supply is delivered to the unit; if this LED is switched off, this supply is absent or the protection fuse is blown.

- T.B.D. -