

FILLBOX FLUX

Filling control module

Datasheet

Description

Filling control module. Main characteristics:

- Two filling heads control.
- 10 digital outputs, 500 mA max.
- 6 Type 1 and Type 3 compatible digital inputs.
- 2 I/O (digital inputs or digital outputs same as above)
- Ethernet interface.
- Industry standard M12 connections.
- Compact IP64 plastic housing.

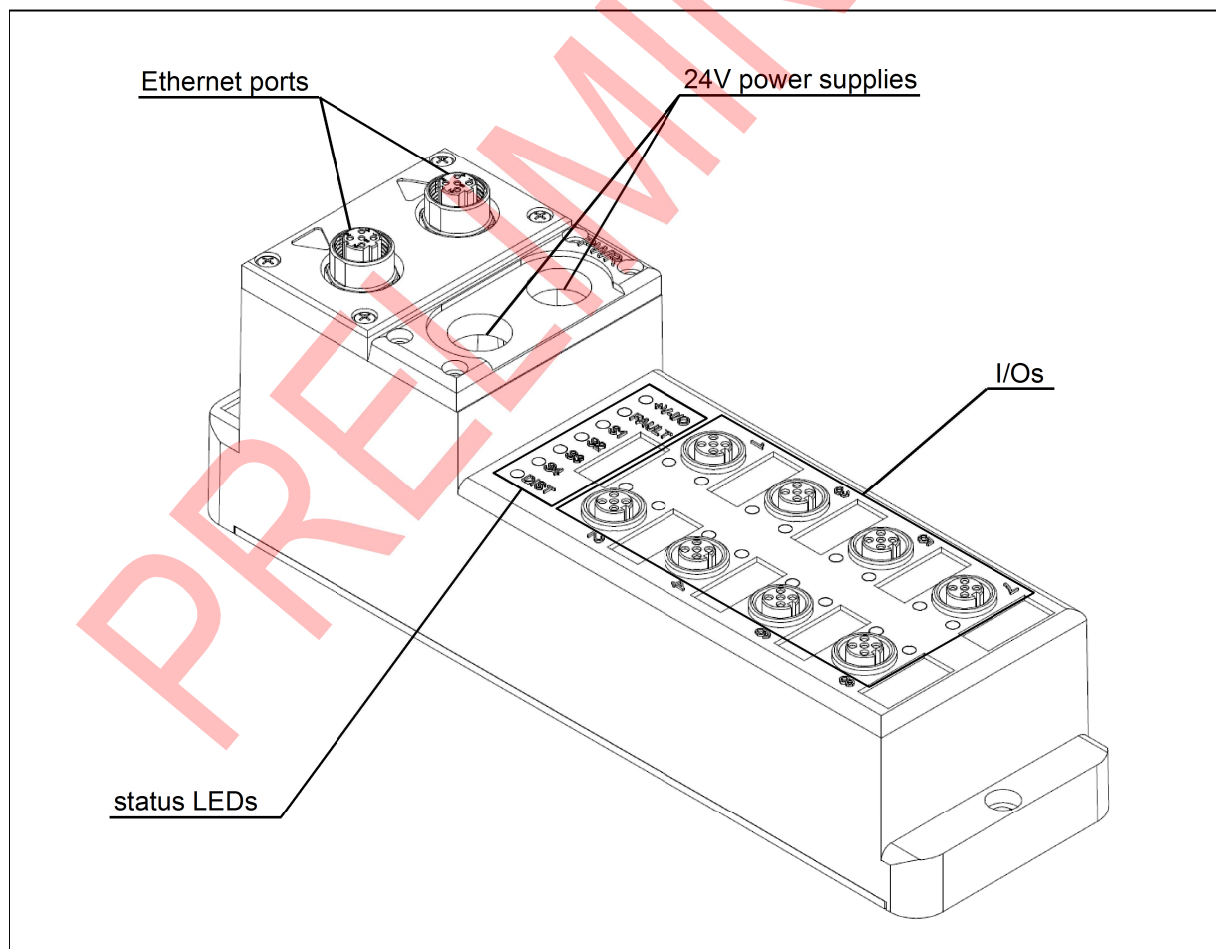

Ordering informations

Products	SMITEC part number
FILLBOX FLUX module	KZ010314

Accessories	SMITEC part number
Power supply connector (Weidmuller 1580450000)	KF100000
M12 sealing plug	EP200068
PG-9 cable gland (for power supply connector)	EK500055
PG-9 sealing plug	EK500223

Documentation	SMITEC part number
Datasheet for KZ010314 (english)	DK400096

Technical data

General data	
Housing dimensions (length x width x height)	220 x 63 x 72 mm
Weight	0.53 kg
Permissible operating temperature	+5°C to + 55°C
Permissible storage temperature	-40°C to +70°C
Permissible humidity	5% to 95%, not condensing
Permissible air pressure (operation)	80 to 106 kPa (up to 2000 m above sea level)
Permissible air pressure (storage)	70 to 106 kPa (up to 3000 m above sea level)
Degree of protection	IP64 according to IEC 60529
Wiring method for power supply connector	Screw terminals
Conductors cross-section	0.1 to 2.5 mm ² (27÷12 AWG), stranded wire
Functional earth connection	By supply connector

Power supplies	
Number of supplies	2
Logic power supply	20.4 ÷ 28.8 VDC according to IEC 61131-2
Maximum allowed ripple on logic supply	5% of nominal voltage according to IEC 61131-2
Current consumption on logic supply	400 mA max.
Overcurrent protection on logic supply	PTC resettable fuse
I/O power supply	20.4 ÷ 28.8 VDC according to IEC 61131-2
Maximum allowed ripple on I/O supply	5% of nominal voltage according to IEC 61131-2
Current consumption on I/O supply	8 A max.
Overcurrent protection on I/O supply	5 x 20 mm fuse, 10 A max.
Main power connector current carrying capacity	12 A max.

Digital inputs	
Number of inputs	6 fixed + 2 instead of digital outputs
Number of standard inputs	6
Number of fast inputs	2
Nominal input voltage	24 VDC
Nominal input current	2.5 mA
Inputs design	According to IEC 61131-2 Type 1 and Type 3 (also Type 2 with external resistor)
Maximum low level threshold	5 V
Minimum high level threshold	11 V
Fast inputs bandwidth	12 kHz max.

Digital outputs	
Number of outputs	10 fixed + 2 instead of digital inputs
Type of outputs	Digital 24 V
Outputs design	High-side MOSFET with integrated Zener clamp
Outputs rated current	500 mA max.
Protections	Overload, short circuit and overtemperature
Inductive loads special functions	Fast demagnetization

Fieldbus	
Fieldbus	Ethernet
Module address setting	Auto assignment
Bus connections	By D-coded M12 connectors

Miscellaneous	
I/O visual indicators	Amber LED lamps, lighted if corresponding I/O is on (except for auxiliary output 3)
Module status visual indicators	6 LED lamps

Introduction

This module is a programmable control unit, able to manage two filling heads in industrial bottling machines.

Each filling channel is provided with five 24V digital outputs (output current 500 mA max.): two for batch and pre-batch valves driving and three for auxiliary purposes. Also four digital inputs are available (Type 1 and Type 3 compatible, as defined in IEC 61131-2) for each one: one is fast enough to accommodate a digital flowmeter, and three are general purpose for diagnostic or auxiliary purposes. A standard Ethernet interface is used for communication purposes. Small size and sealed housing render it particularly suited for a mounting on the machine's chassis, reducing the length of the cables.

Connections

This module has several connectors for the power supplies, the I/Os and the fieldbus (depicted in the illustration). See the following chapters for a more detailed description of these.

Power supplies

The power supply connector is easily reachable removing the small plastic plate located on the upper side of the housing, secured by four M3 crosshead screws. Cable sealing is obtained using two PG-9 cable glands; whenever only one cable is used, seal the unused opening screwing in the suited sealing plug. The device needs two different power supplies; one feeds the logic section of the device, and one the power stages and the sensors; the greater amount of power is usually drawn by the I/O supply, and an internal 5 x 20 mm fuse acts as an overcurrent/overload protection. In several situations, it is customary to use an UPS to backup the logic power supply, particularly whenever the I/O supply could be interrupted by external events (e.g. an emergency button or a door switch). If the user doesn't need this feature, the two supplies can be shorted together. If several modules should be fed by the same power supply, two different wiring topologies could be employed: a point-to-point and a daisy-chain topology. Point-to-point wiring means that each device is fed by the PSU via its own cable; all cables are tied together at the origin. Daisy-chaining stands for a series connection of the modules; each of them is fed by the

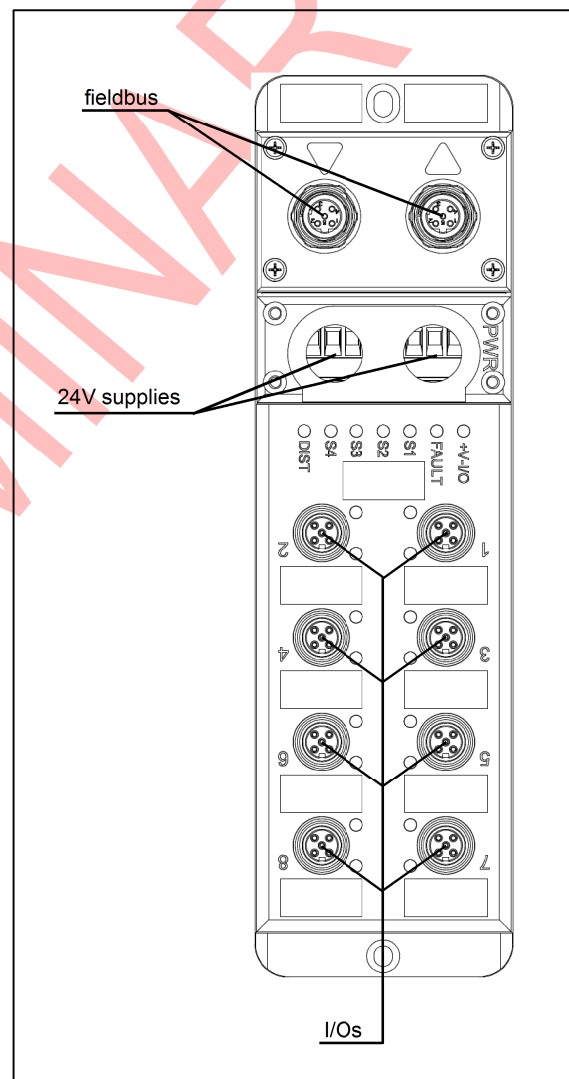

previous device and, in turn, it feeds the following one. This topology is particularly useful when there are many devices and/or they are very far from the PSU. The principal drawback of this kind of wiring is that the upstream conductor has to bear the whole current, so this topology can be used only where the total power is limited. Whenever the total current passes through a connector, special care has to be exerted to avoid damaging of this one, especially during a fault.

The pinout of the supply connector is depicted aside; as previously stated, power supply pins are split, so easing wiring in a daisy-chaining fashion. Please notice the presence of a separated earth contact, used to connect the shield of the I/O cables and for EMC filtering purposes.

To avoid failures or incorrect operation of the modules, the PSU ground should be equipotential with earth; to avoid the generation of detrimental ground loops, the ground contact should be earthed only once in the electrical cabinet, and the impedance of the earth connections should be kept low enough to effectively drain RF noise.

The following illustration shows the recommended wiring for point-to-point topology:

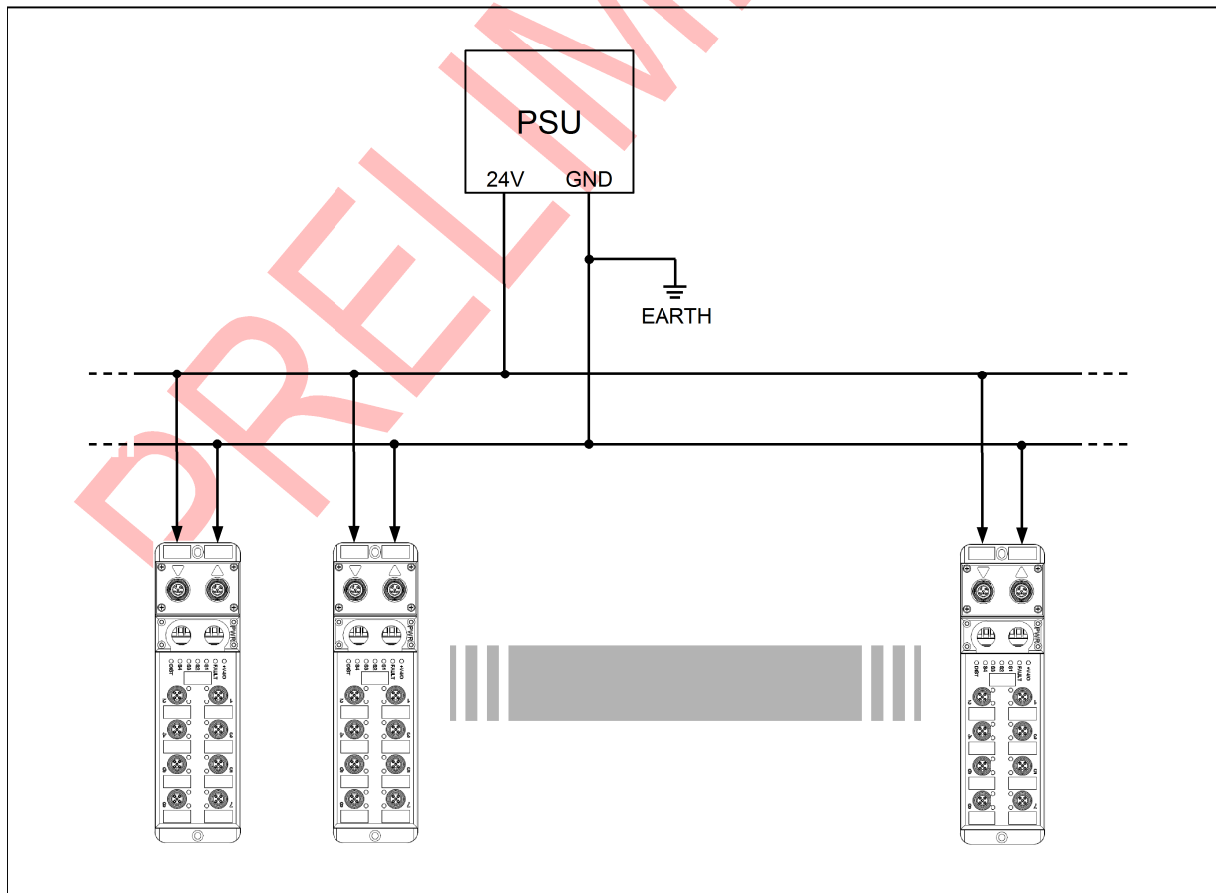
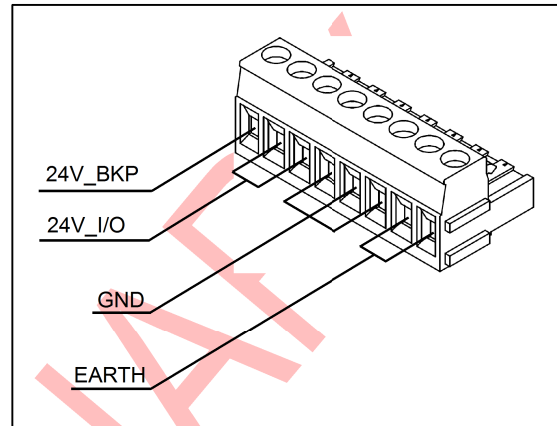

An example of daisy-chain topology is instead depicted in the following illustration; for simplicity, in each example only one PSU is shown.

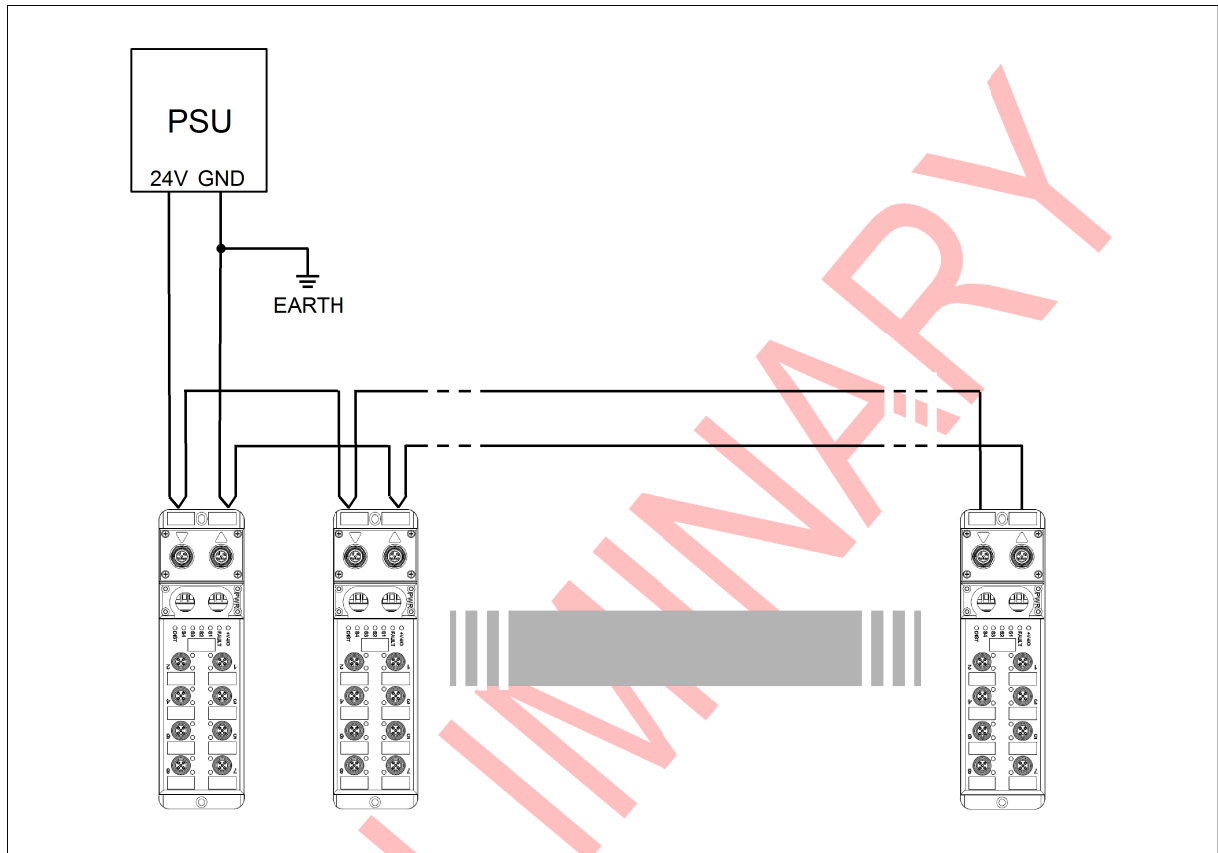

Whenever necessity of split power supplies arises (eg. when using a backup logic supply), the same wiring rules apply to each one.

Inputs/Outputs

As stated before, the unit owns two identical filling channels; each one is provided with four inputs and five outputs. The M12 connectors of each head are aligned along a row, to ease wiring and avoid connection mistakes during service. Each connector is marked with a number molded in relief on the housing; see illustration for the numbering pattern:

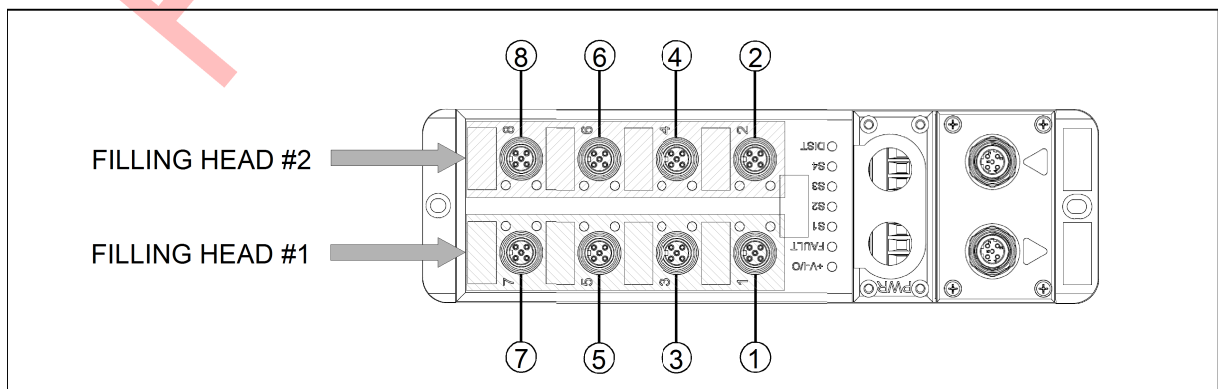

The following table resumes the functions of each pin:

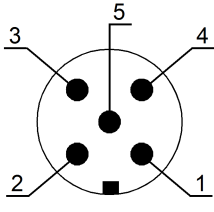
	CONNECTOR NUMBER			
	1 – 2	3 – 4	5 – 6	7 - 8
PIN NUMBER	1 – 2	3 – 4	5 – 6	7 - 8
1	24V	24V	auxiliary output 3	24V
2	diagnostic input	auxiliary input 2	auxiliary output 2	batch output
3	GND	GND	GND	GND
4	flowmeter input	auxiliary input 1 or auxiliary output 4	auxiliary output 1	pre-batch output
5	shield	shield	shield	shield

The I/O function on pin 4 of connector 3 and 4 are independently configurable by user process control software.

Each I/O, except auxiliary output 3, are provided with an amber status LED, which is lighted when the corresponding input/output is at logic level “1”.

Digital inputs, in an effort to render them compatible with the great majority of sensors available on the market, are compliant with Type 1 and Type 3 inputs, as defined in IEC 61131-2. Type 1 characteristics are thought primarily for mechanical contact switches (such as contact relays, push buttons, switches, etc..), whilst Type 3 characteristics are mostly suited for solid state switching devices (i.e. devices with semiconductor-driven output). Flowmeter inputs, due to the relative high number of pulses per unit of time delivered by these sensors, are characterized by a quite high analog bandwidth. This characteristic renders them markedly susceptible to electrical noise, so the use of shielded cable is highly recommended. The following illustration depicts the recommended wiring for a digital sensor (such as a flowmeter); please notice that the cable sheath is tied to earth for noise reduction purposes.

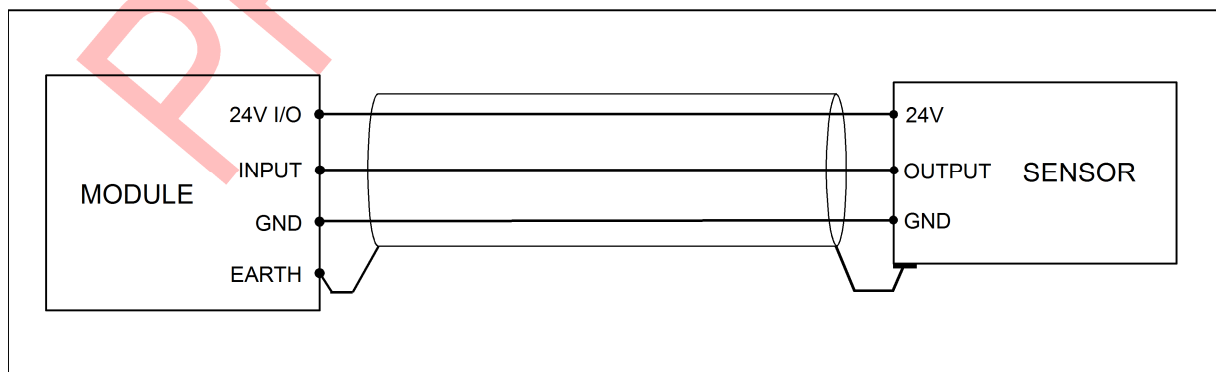

Even whether this arrangement is highly desirable, particularly in harsh industrial environment, it can be avoided where electrical noise is not of concern.

Digital outputs are made with a p-channel MOSFET, so they are unable to sink current from the load. This particular arrangement is used to allow the implementation of a fast-demagnetization feature, which speeds up the decay of the current in an inductive load (such as relay coils, valves, etc.). This mode of operation, however, provokes a power dissipation in the output stages, so great care should be used whenever a high commutation speed and/or highly inductive loads are concerned. If the amount of power inside the housing becomes unbearable, an external freewheeling diode should be paralleled across the output; therefore, the load recirculating current flows in the external diode. Due to the limited voltage across the diode, the turn-off time could lengthen excessively, so an accurate examination is needed.

When three general-purpose outputs are available for each filling channel, the outputs for pre-batch and batch valves are unambiguously defined and share a separated connector.

The 24V power supply available on the connectors is thought for feeding sensors or external electronic devices and, in case of an overload or a short circuit, an internal 5 x 20 mm fuse protects the cables and the electronics. The following illustration shows a recommended wiring schematic for a typical actuator. In this case, unless the risk of disturbing noise-sensitive nearby devices is substantial, the wiring could be made with ordinary non shielded cable.

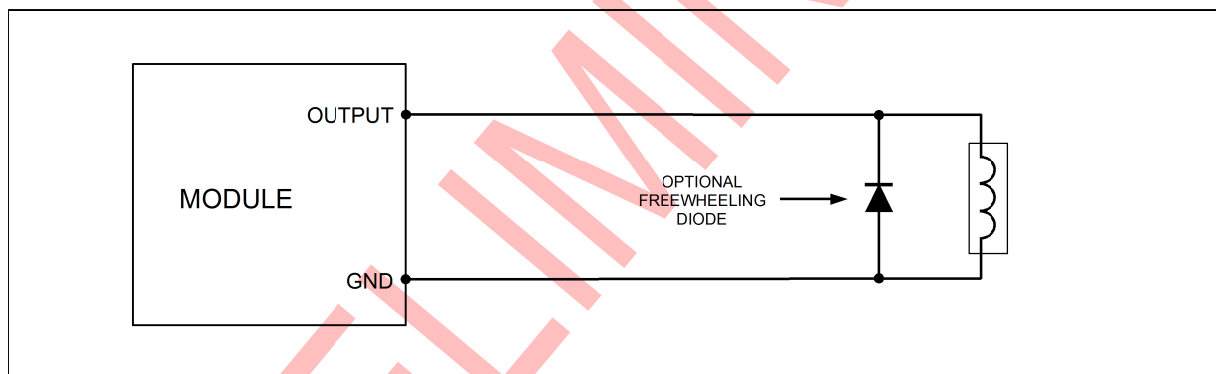

Fieldbus

This module is provided with an Ethernet interface; the connections of the fieldbus are available through two purposely made D-coded M12 connectors; the pinout is depicted in the illustration. The wiring of the fieldbus network should be done with standard CAT 5E Ethernet cable. Due to the address auto-assignment system, the wiring order of the modules should be respected or an erroneous addressing will result. The two arrows etched aside the fieldbus connectors indicate that this cable come from the preceding device or goes to the next device.

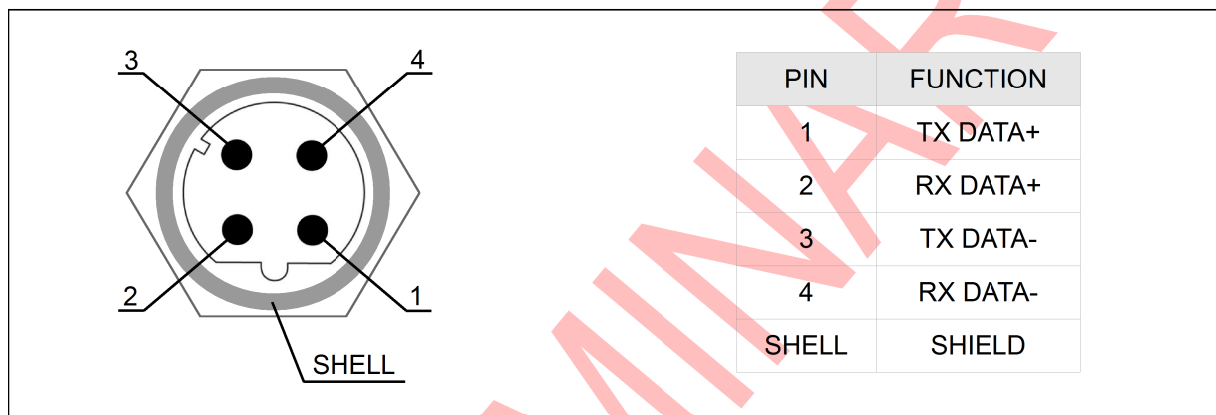

Module status

The status of the module is clearly shown by the status of six LED lamps; their colour and behaviour (being them turned on, turned off or blinking in a definite manner) indicate if the unit is working correctly or it is faulty and, in this case, where the problem lies.

The 24V_I/O lamp is lighted when the main power supply is delivered to the unit; if this LED is switched off, this supply is absent or the protection fuse is blown.

The following table resumes all the possible situations encountered during operation:

FAULT	S1	S2	S3	S4	STATUS
off	fixed green	-	-	-	correct operation, application dependent
off	fixed orange	-	-	-	
off	fixed red	-	-	-	
red	blinking (error code)	-	-	-	HW fatal error
off	blinking (error code)	-	-	-	application-dependending error
-	-	fixed green	-	-	at least one TCP/IP connection active
-	-	fixed orange	-	-	one MODBUS TCP/IP valid packet received
-	-	fixed red	-	-	not used
-	-	-	green	-	LINK (Ethernet port 1)
-	-	-	orange	-	ACTIVITY (Ethernet port 1)
-	-	-	-	green	LINK (Ethernet port 2)
-	-	-	-	orange	ACTIVITY (Ethernet port 2)

S1 lamp flashes in a peculiar manner to indicate an error (each error is associated to a number, comprised between 1 and 99).

The pattern is as follows: first the lamp is turned red for a small amount of time, then it is switched off. After this, it delivers a number of orange blinks corresponding to the tens and a number of green blinks corresponding to the units. Now all the lamps are turned off for a small time, and the signaling pattern is then repeated endlessly.

For instance, a pattern composed by one red blink, three orange blinks and five green blinks indicates error 35.

See the relevant documentation for the meaning of the various errors.