

CPC 01/02

x86 Computer Module

Datasheet

Description

Module CPC 01/02 consists in a x86 architecture computer with SDVL (SMITEC Digital Video Link) for HMI operations.

Main characteristics:

- Intel Atom Z510 (CPC 01) / Z530 (CPC 02) processor and US15W chipset
- 1GB DDR2 533MHz RAM
- one 10/100/1000 Mbps ethernet, one RS232/422/485, one local and 2 remote 2.0 USB, one analog and one digital video output
- one Compact Flash Card socket

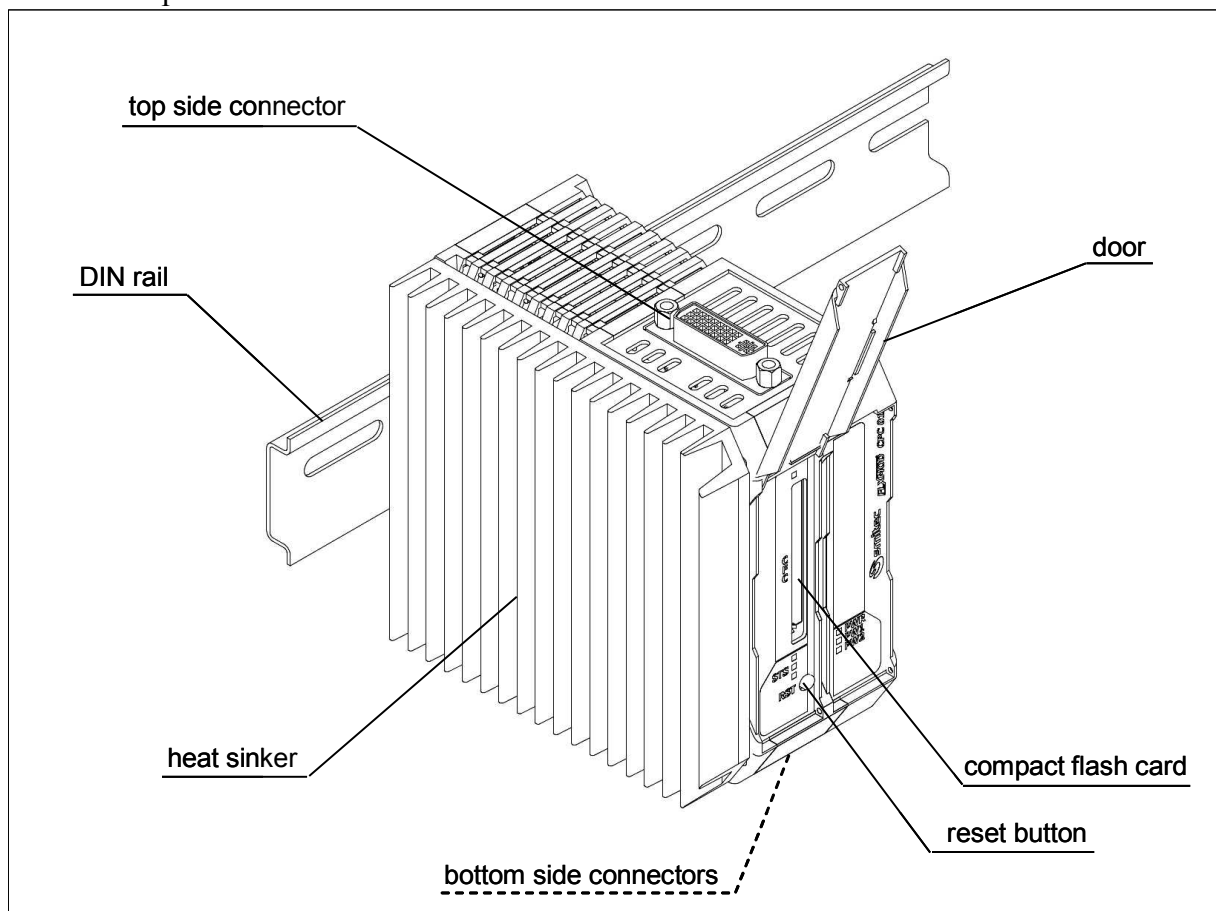

Ordering informations

Products	SMITEC part number
X86 computer module with Intel Atom Z510 processor, complete with power connector	KZ010251
X86 computer module with Intel Atom Z530 processor, complete with power connector	KZ010267

Accessories	SMITEC part number
Power supply connector (Phoenix Contact p/n 1910377)	KF100009
Power supply fuse (Littelfuse p/n 0452 005)	KD200038
256MB Industrial grade Compact Flash Card fixed	KE020019
1GB Industrial grade Compact Flash Card fixed	KE020016
2GB Industrial grade Compact Flash Card fixed	KE020015
4GB Industrial grade Compact Flash Card fixed	KE020025
DVI-I to analog video adapter	EP200308
SDVL cable length 3m	EC100200
SDVL cable length 5m	EC100201

Documentation	SMITEC part number
Installing instructions for CPC 01/02 (multilanguage)	DK400081
Datasheet for CPC 01/02 (english)	DK400080
FLXMOD system integration manual (english)	DK400076

Technical data

General data	
Housing dimensions (width x height x depth)	60.0 mm x 99.0 mm x 114.5 mm
Weight	440 g (without Compact Flash Card), 450 g (with Compact Flash Card)
Permissible operating temperature	+5° to +55°C
Permissible storage and transport temperature	-25° to +85°C
Permissible humidity	10% to 95%, not condensing
Permissible air pressure (operation)	80 to 106 kPa (up to 2000 m above sea level)
Permissible air pressure (storage and transport)	70 to 106 kPa (up to 3000 m above sea level)
Degree of protection	IP20 according to IEC 60529
Connection method for power connector	Spring cage terminals
Conductor cross-section for power connector	0.2 to 2.5 mm ² (24 – 12 AWG)
Recommended cable for COM connection	Ethernet FTP Cat. 5E
Recommended cable for SDVL connection	Dual link DVI with ferrite chokes
Functional earth connection	To the DIN rail with spring contact
Mode state visual indicators	Status (STS), power (PWR, BP1, BP2) LED lamps on front panel

Power supply	
Main power supply V_M	24 V DC (-15% ÷ + 20% according to IEC 61131-2)
Maximum allowed ripple	5% of supply voltage (according to IEC 61131-2)
Current consumption from main supply	0,3 A max.
Supply overvoltage protection on V_M	Unidirectional Zener clamp ($V_z > 30$ V)
Supply reverse polarity protection	Input shunt diode, reverse connected
Supply fuse	5 A
Power presence visual indicators	Green LED lamp, lighted if main supply is present (PWR)
Internal power #1	5 V DC / 3 A, regulated
Internal power #1 protections	Overcurrent, catastrophic overvoltage
Internal power #1 visual indicators	Green LED lamp, lighted if supply is present (PW1)
Internal power #2	24 V DC / 2 A, unregulated
Internal power #2 protections	Overcurrent
Internal power #2 visual indicators	Green LED lamp, lighted if supply is present (PW2)

Computer	
Microprocessor	Intel Atom Z510 (CPC 01) Intel Atom Z530 (CPC 02)
Chipset	US15W
Graphic	Chipset integrated Graphic Media Accelerator 500, 18-24 bpp
RAM	1GB DDR2 533MHz
Mass memory	Front removable 256MB industrial grade Compact Flash Card
COM port	Dip-switch selectable RS232/422/485 through RJ45 connector
Ethernet	10/100/1000 Mbps through RJ45 connector
Video output	Analog and digital through SDVL (SMITEC Digital Video Link) connector (DVI-I type)
State visual indicators	One red, one orange and one green LED lamp for global status configurable by application software and with reprogrammable firmware; one orange LED lamp for CFC accessing
Other	Front reset button, display brightness dimming function, internal temperature reading

Connections

The module CPC 01/02 has several connectors for connecting peripherals and the power supply. Some of these are located on the bottom side of the module (power supply, Ethernet, COM and its setup dip-switch, local USB); on the upper side there is the SDVL connector. The Compact Flash Card socket is located frontally under the transparent protection cover, together with the reset button.



Warning: CPC 01/02 module is an electronic high technology device with numerous connectors; for these reasons it result a ESD sensitive device. Observe ESD mitigation techniques or damage might occur.

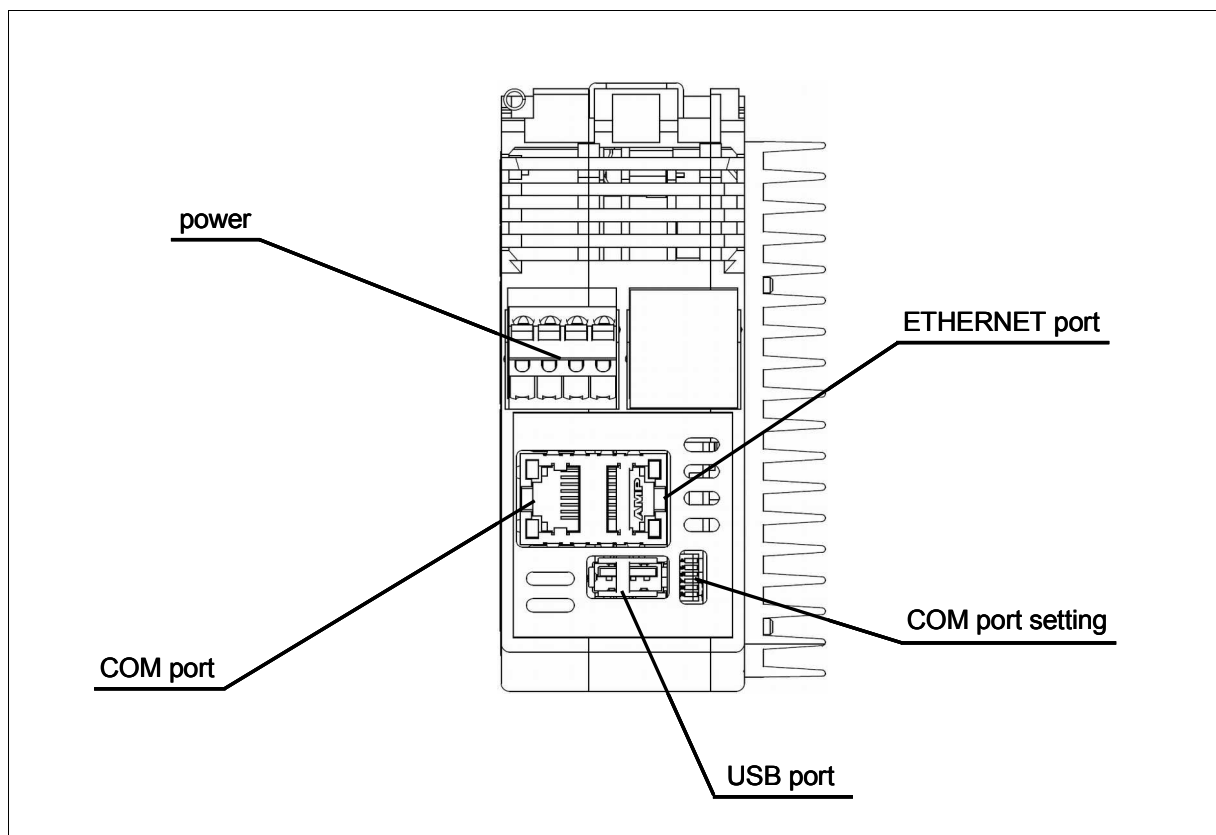

Power connector

The power connector is located on the bottom side of the module. Here its pinout:



Warning: Use a cable with cross-section suited to the current involved. A wire smaller than necessary could cause risk of fire and unwanted voltage drops.



Warning: To ensure conformance with EMC directive 89/336/EEC, the length of the cables must not exceed 30 m!

Refer to the FLXMOD System Integration Manual for power connections topology.

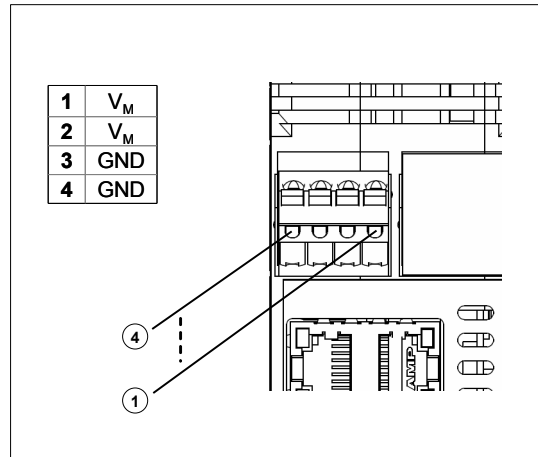

Ethernet connector

The ethernet connector is located on the bottom side of the module. Its pinout is standard for 10/100/1000 Gbps ethernet. In this way is possible employ common ethernet cable to connect the MST S3 to the network.

COM connector

For compactness of the module, the COM connector is not a standard 9 pin D-Sub but a RJ45; for the same reason not all the standard RS232 signals are carried out. The connector is located on the bottom side of the module; here its pinout.

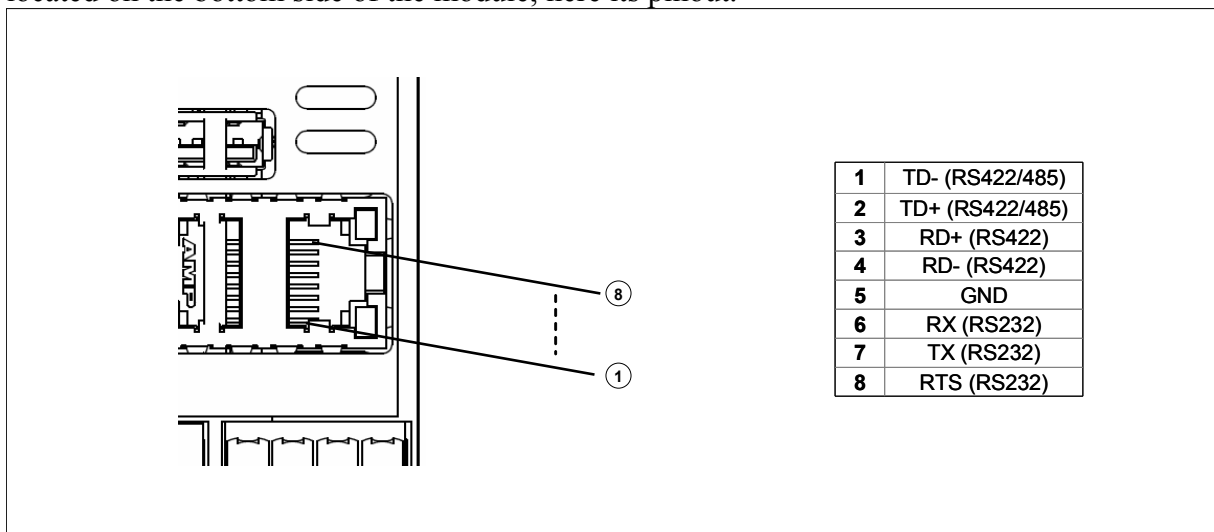

COM setup DIP-SWITCH

Ever on bottom side of the module there is a 6 ways dip-switch that permits to setup the COM mode (RS232, RS422, RS485 w and w/o echo). Here the valid configurations:

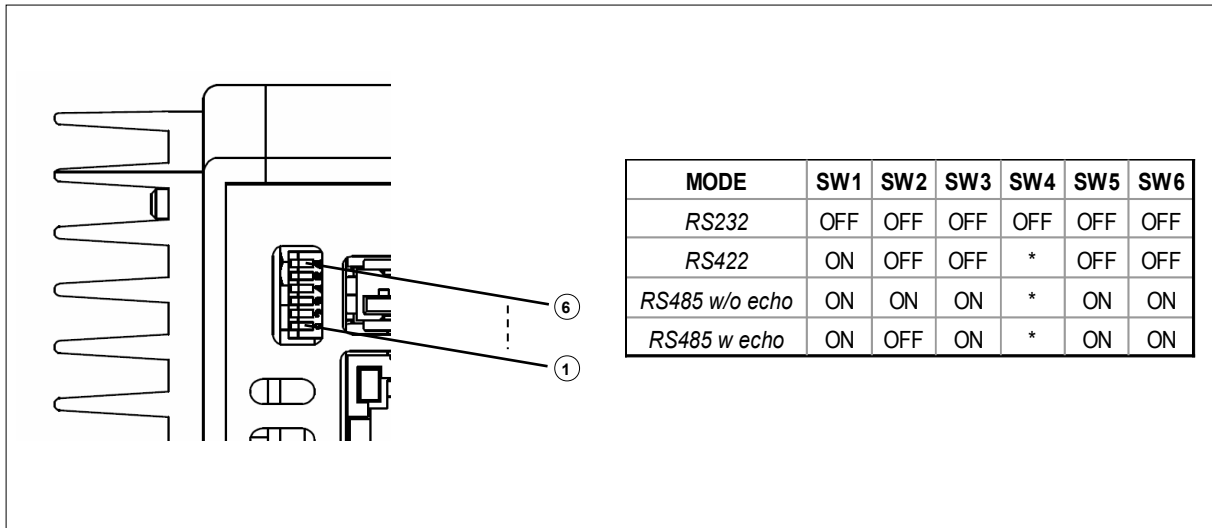

* = This switch activate (ON) or deactivate (OFF) the resistor termination of receiver line; set it as application needs.



Warning: wrong configuration may cause damage to the device connected to the CPC 01/02 or to the CPC 01/02 itself.



Warning: wrong configuration may cause communication data corruption.

USB connector

The USB connector is located on the bottom side of the module. Its pinout and use is the same of the USB that are present in common computers.

SDVL connector

This connector is located on the upper side of the module and physically is DVI-I type.

SDVL is the acronym of SMITEC Digital Video Link that is a proprietary type of connection for SMITEC HMI graphic devices; this type of connection shares with a standard DVI-I connection only the physical connector, standard dual link cable to connect the proprietary devices and the analog signal to connect common monitors (CRT or LCD).

SDVL support displays up to 1024x768 pixels at 24 bpp and brightness control signal; it also carries out 2 USB ports.

In order to connect a standard monitor with the analog input signals to the SDVL connector it is enough to use a common DVI-I > VGA (male > female) adapter.



Warning: connecting a standard DVI monitor to SDVL output may cause damage to the device or to the CPC 01/02 itself.



Warning: plugging or unplugging the SDVL cable where the system is powered may cause system damage. Never do it unless the power supply is switched off in this module and in the HMI module.

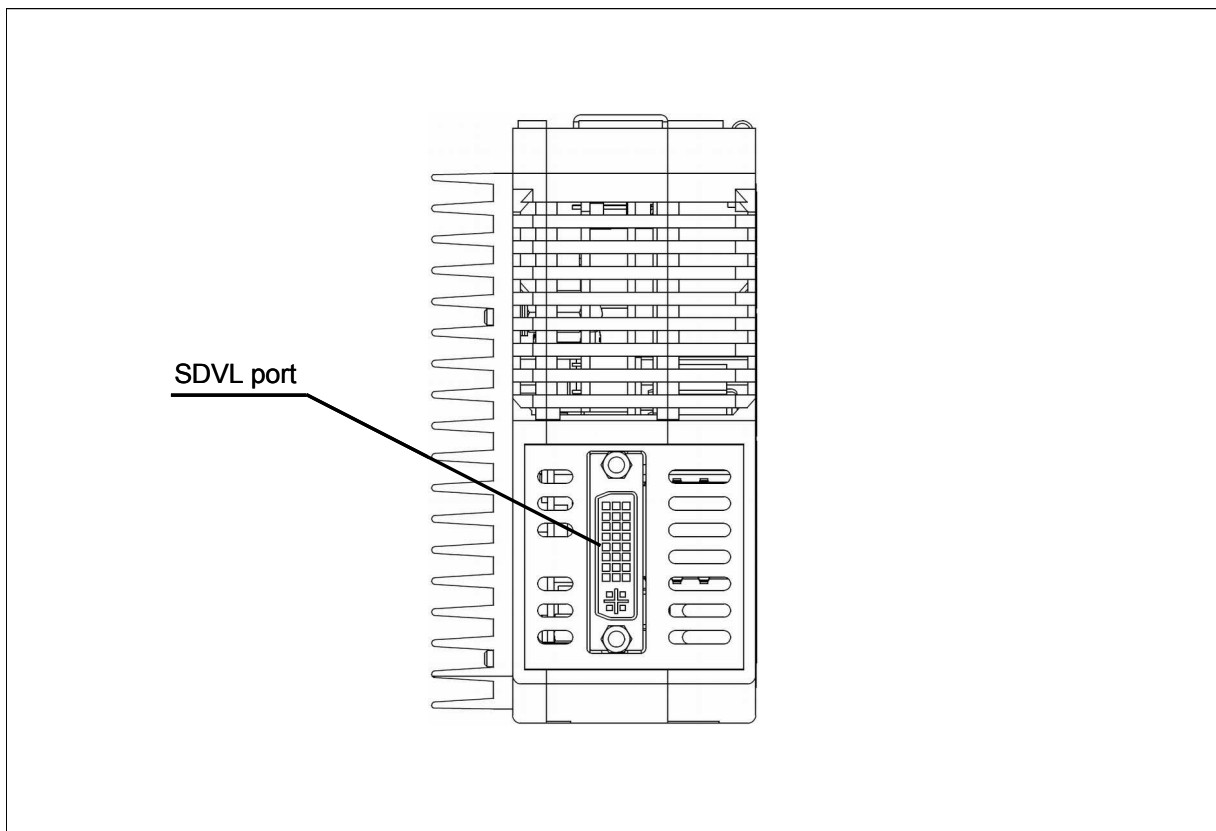

Compact Flash Card socket

This socket (**CFC**) is internal to the MST module and it allow to connect frontally to it a type I Compact Flash Card; to insert or remove the card is necessary to open the most left transparent protection cover of the module, then push in the device deeply / pull out the device by its rib and close the cover again to secure the card at its place.

Reset button

The reset button (**RST**) is usefull to restart the computer without power off then on the module. It is frontally to the module under the most left transparent protection cover. It is recommended to close again the cover after the reset button use to secure the Compact Flash Card at its place.

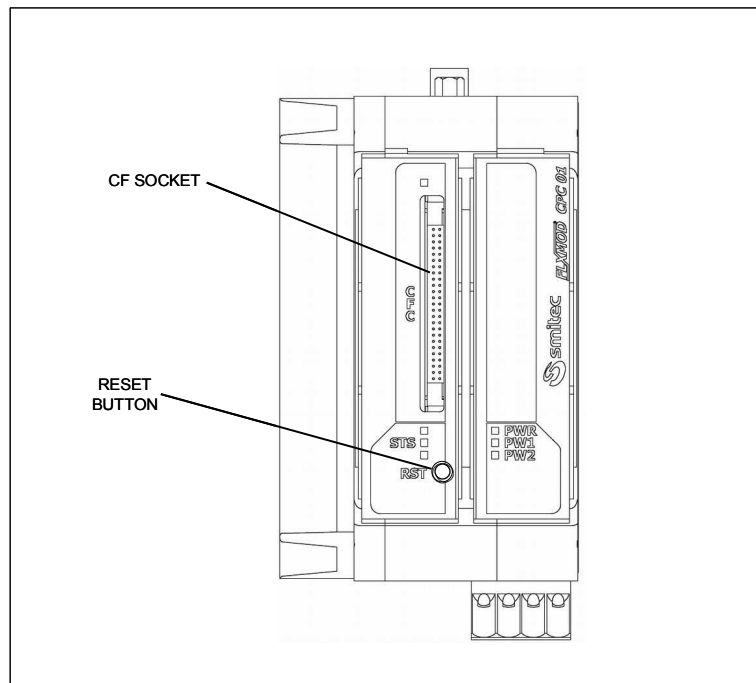

Diagnostic and status indicators

Each module is provided with a series of LED lamps on the front panel (see illustration), that indicates the status of the unit and a possible diagnostic warning. For the sake of clarity, different lamp colours are employed.

The green LED **PWR** is lighted if the 24 V supply (V_M) is present and the internal fuse is not blown.

The green LEDs **PW1** and **PW2** indicate, if lighted, that the internal supplies are working correctly.

The orange LED **CFC**, when lighted, indicates that the system access to the Compact Flash Card.

The status of the unit is indicated by the **STS** LEDs; their behaviour may vary according to application software that is running. Anyway there are few factory default behaviours that are:

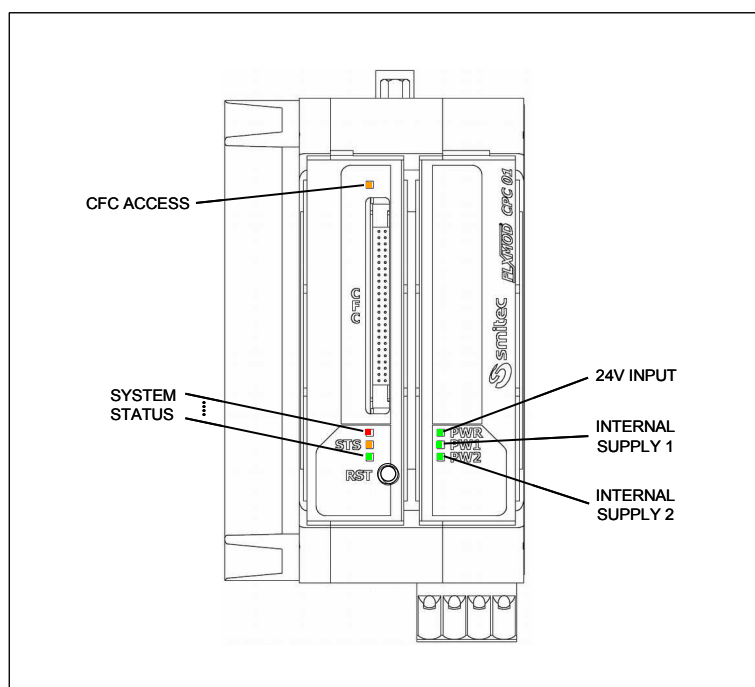

- RED on, ORANGE and GREEN off = system faulty
- RED on, ORANGE and GREEN flash together then GREEN flash one time then ORANGE and GREEN flash together and so on = application software not running or operative system not started
- RED, ORANGE and GREEN on = system is starting
- RED flashing quickly, ORANGE and GREEN off = system is updating the internal firmware